

HIGHLEAD

**GC0318-2A/GC0318-2H/GC0318-2B/
GC0318-2AD
TOP AND BOTTOM FEED LOCKSTITCH
SEWING MACHINE**

**Instruction Manual
Parts Catalog**

SHANGHAI HUIGONG NO.3 SEWING MACHINE FACTORY

CONTENTS

1. Instruction Manual

1. MAIN SPECIFICATIONS	2
2. INSTALL THE MOTOR	2
3. CONNECT THE CLUTCH LEVER WITH THE PEDAL	2
4. PREPARATION AND LUBRICATION	3
5. REPLACE NEEDLES	3
6. NEEDLE, THREAD AND MATERIAL TO BE SEWN	4
7. RUN-IN OPERATION	4
8. THREADING	5
9. WINDING ADJUSTMENT	6
10. SET STITCH LENGTH AND REVERSE FEEDING	7
11. POSITION PRESSER BAR	7
12. ADJUST THE PRESSURE OF PRESSER FOOT	8
13. ADJUST THREAD TENSION	8
14. ADJUST THREAD TAKE-UP SPRING	9
15. ADJUST THREAD GUIDE AND THREAD TENSION	10
16. TIME NEEDLE TO ROTATING HOOK	11
17. REPLACE ROTATING HOOK	12
18. ADJUST THE HEIGHT OF FEED DOG	12
19. ADJUST THE POSITION OF FEED DOG	13
20. TIME FEED MOTION TO NEEDLE MOTION	13
21. ADJUST OPENING TIME OF THE TENSION DISCS	14
22. LUBRICATION ADJUSTMENT	15
23. REGULAEANING	16
24. ADJUSTMENT OF THREAD TRIMMER MECHANISM	17

2. Parts Catalog

A. ARM BED AND ITS ACCESSORIES	18
B. NEEDLE BAR AND TAKE-UP, ARM SHAFT AND VERTICAL SHAFT MECHANISM	21
C. STITCH REGULATOR MECHANISM	25
D. FEEDING AND FEED LIFTING MECHANISM	28
E. PRESSER FOOT MECHANISM	30
F. PRESSER LIFTING, FEEDING MECHANISM	32
G. LUBRICATION MECHANISM	35
H. THREAD TRIMMER MECHANISM	37
I. TOUCH BACK MECHANISM & DETECTOR MECHANISM	40
J. OIL RESERVOIR AND OTHER ACCESSORIES	42

1. MAIN SPECIFICATIONS

Item	GC0318-2A	GC0318-2H	GC0318-2B	GC0318-2AD
Max. sewing speed (spm)	2000	2000	2000	2000
Needle	DP×17 18 [#] -22 [#]	DP×5 14 [#]	DP×17 25 [#]	DP×17 18 [#] -22 [#]
Needle bar stroke (mm)	35	35	35	35
Lubrication	Automatic	Automatic	Automatic	Automatic
Stitch length (mm)	0-10	0-4	0-10	0-8
Presser foot lift	by hand (mm)	6	6	6
	by knee (mm)	13	13	13

2. INSTALL THE MOTOR (Fig.1)

Align Motor Pulley Groove (B) and Balance Wheel Groove (A) by moving the motor leftward or rightward.

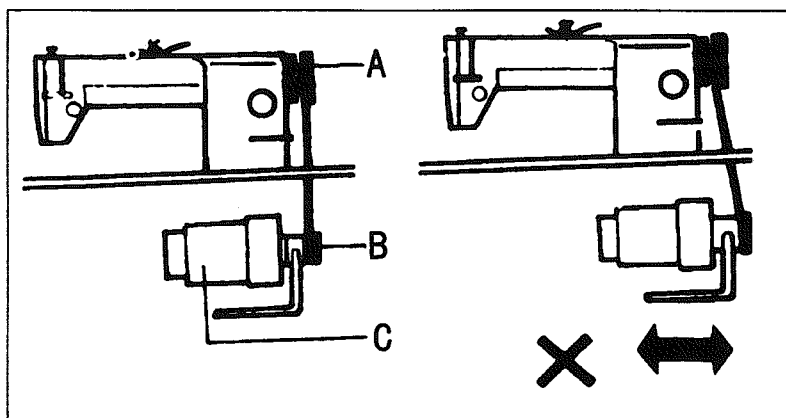

Fig. 1

3. CONNECT THE CLUTCH LEVER WITH THE PEDAL (Fig.2)

- 1) The optimum tilt angle of pedal (A) is approximately 15 deg.
- 2) Adjust Clutch Cover (D) so that Clutch-Lever (C) and Draw Bar (B) run in line.
- 3) The balance wheel should rotate counter-clockwise when viewed from the outside of Balance Wheel (G).
The direction of the motor pulley rotation can be reversed by reversing (turning over 180 deg .) the power plug of the motor.
- 4) Adjust the tension of V-belt (F) by turning Motor Vertical Position Screw (E).
The proper tension of the V-belt is a slack of 10-20mm when the belt is depressed at the center of the belt by finger.

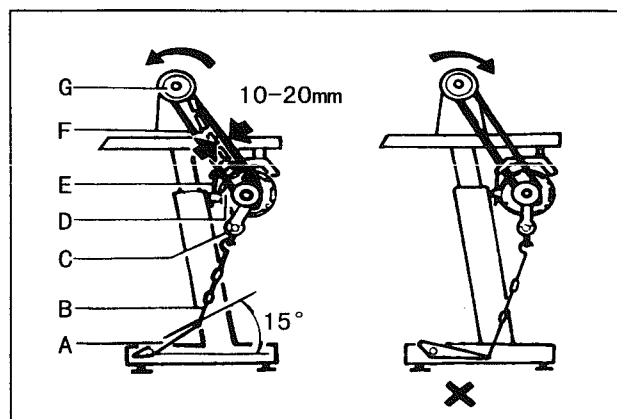

Fig. 2

4、 Adjustment of needle bar stop position(Fig3):

1) Adjustment of “UP” position

When the pedal is kicked down by heel to cut the thread, the machine stops in the “UP” position. If the marks deviate more than 3mm, adjust as follows:

- (1) Disconnect the plug (12 pins) from the control panel;
- (2) Run the machine and stop in the “UP” position;
- (3) While holding the pulley, insert the adjusting tool into the two holes marked “A”, then rotate the pulley.

2) Adjustment of “DOWN” position

When the pedal is returned to the neutral position, the machine stops in the “DOWN” position. If the marks deviate more than 3mm, adjust as follows:

- (1) Disconnect the plug (12 pins) from the control panel;
 - (2) Run the machine and stop in the “DOWN” position;
 - (3) While holding the pulley, insert the adjusting tool into the two holes marked “B”, then rotate the pulley.
- 3) Confirm the stop operation then the plug (12 pins) coming from the machine head into the receptacle.

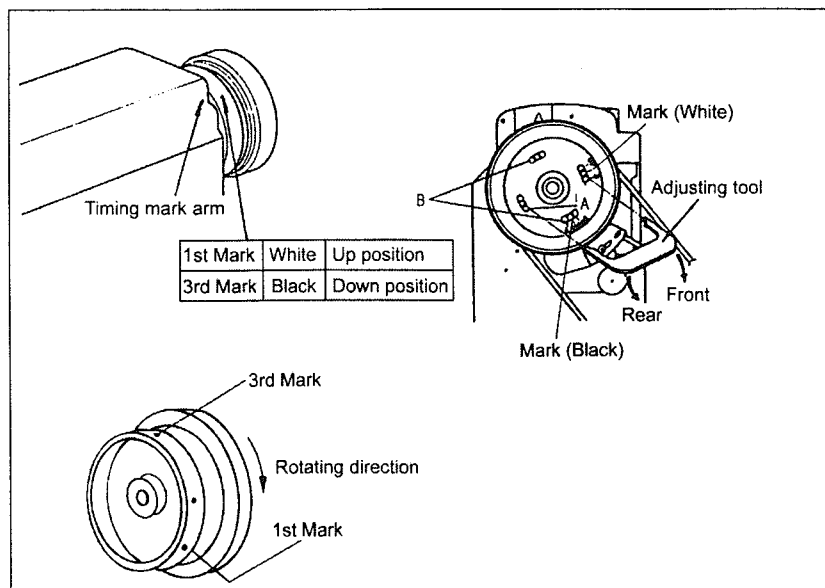

Fig. 3

5. PREPARATION AND LUBRICATION (Fig.4)

1) Cleaning the machine

Before leaving the factory, the machine parts are coated with rust-preventive grease, which may be hardened and contaminated by dust during storage and shipment. This grease must be removed with gasoline.

2) Examination

Though every machine is confirmed by strict inspection and test before leaving the factory, the machine parts may be loose or deformed after long distance transportation with jolt. A thorough examination must be performed after cleaning the machine. Turn the balance wheel to see if there is running obstruction, parts collision, uneven resistance or abnormal noise. If these exist, adjustment must be made accordingly before run-in operation.

3) Oiling

(1) Required amount of oil.

Line (A) on the oil reservoir: Max. oil level.

Line (B) on the oil reservoir: Min. oil level.

If oil level goes down under line (B), oil cannot be distributed to each part of the machine, thus causing the parts a seizure.

(2) Replenishing

Always use only No.18 special machine oil for high speed sewing. Be sure to replenish oil to Line (A) before starting operation.

(3) Replacing oil

To replace oil, remove Screw (C) to drain oil. After completely draining off oil, clean the oil reservoir and securely tighten Screw (C), then fill the reservoir with fresh oil.

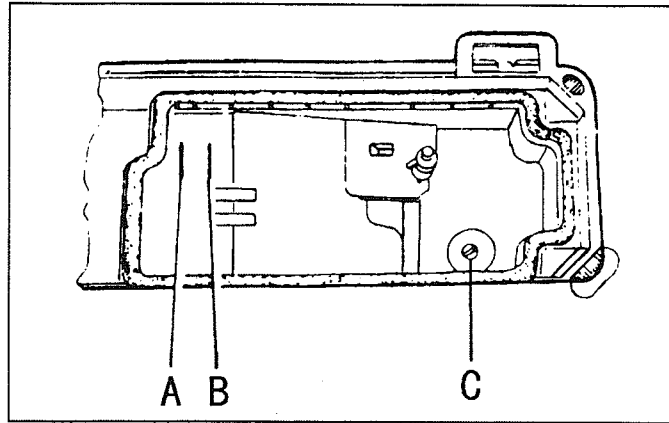

Fig. 4

6. REPLACE NEEDLES (Fig.5)

Turn the balance wheel to lift needle bar to the upper end of its stroke. Loosen Needle Clamp Screw 1. While keeping the long groove of the needle leftward fully insert the needle shank up to the bottom of the needle socket. Then tighten Needle Clamp Screw A.

Note: Fig. (b): insufficient insertion.

Fig. (c): wrong direction of long groove.

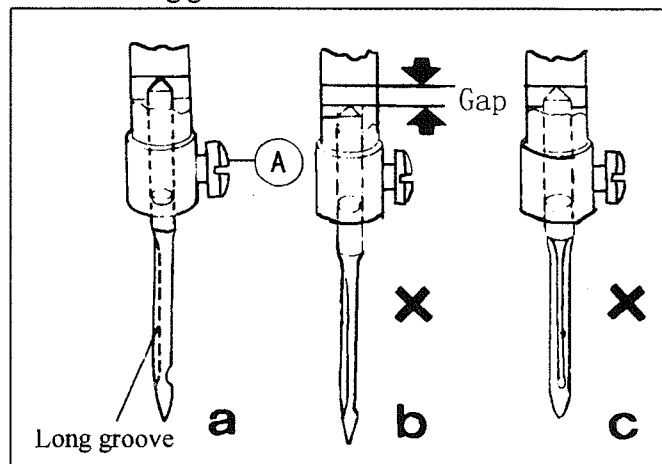

Fig. 5

7. RUN-IN OPERATION (Fig. 6)

Run-in operation is required for a new sewing machine, or a sewing machine left out operation for a considerable length of time.

1) Remove Red Rubber Plugs (A) on the top of the arm and replenish sufficient amount of oil.

2) Lift Presser Foot (B).

3) Run the machine at a low speed (2000-2500spm) to check oil distributing condition through Oil Check Window (C).

4) Perform run-in operation at 2000-2500spm for 30minutes. After a lapse of one month of service during which the working speed is increased gradually and the machine runs sufficiently well, the high speed 5000spm can be adopted according to the nature of the work.

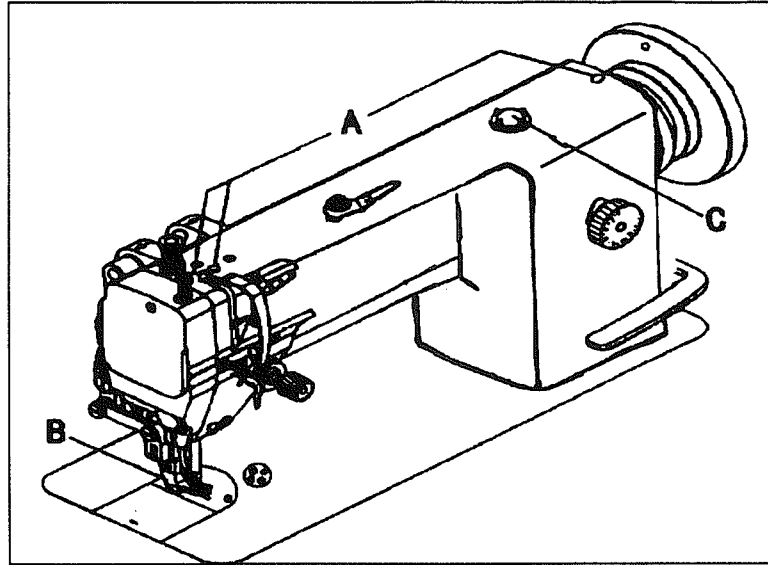

Fig. 6

8. THREADING (Fig.7)

To thread the needle thread, raise needle bar to the upper end of its stroke, lead the thread from spool and perform threading as shown in Fig.7 . To draw the bobbin thread, hold the end of the needle thread and turn the balance wheel to lower the needle bar and then to lift it to its highest position. Pull the needle thread and the bobbin thread is drawn up. Put the ends of needle thread and bobbin thread frontward under presser foot.

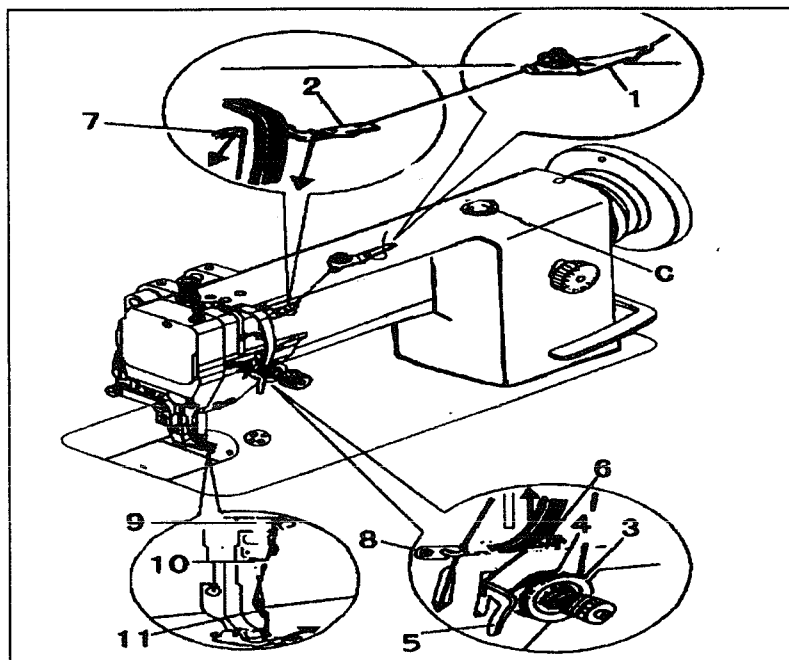

Fig. 7

9. WINDING ADJUSTMENT (Fig.8)

1) The wound bobbin thread should be neat and tight, if not, adjust the winding tension by turning Tension Stud Nut (A) of bobbin winder tension bracket.

Note: nylon or polyester thread should be wound with little tension, otherwise, Bobbin (D) might break or deform.

2) When the wound thread layer does not present a cylindrical shape as shown in Fig.7 (a), loosen Set Screw (B) of bobbin winder tension bracket and slide Bracket (C) leftward or rightward. If thread is wound as shown in Fig.7 (b), move the bracket rightward, but if thread is wound as shown in Fig.7 (c), move the bracket leftward.

After adequately positioning the bracket, tighten Set Screw (B).

3) Do not overfill the bobbin. The optimum length of thread will fill about 80% of bobbin capacity. This can be adjusted by Adjusting Screw (E) of bobbin winder stop latch.

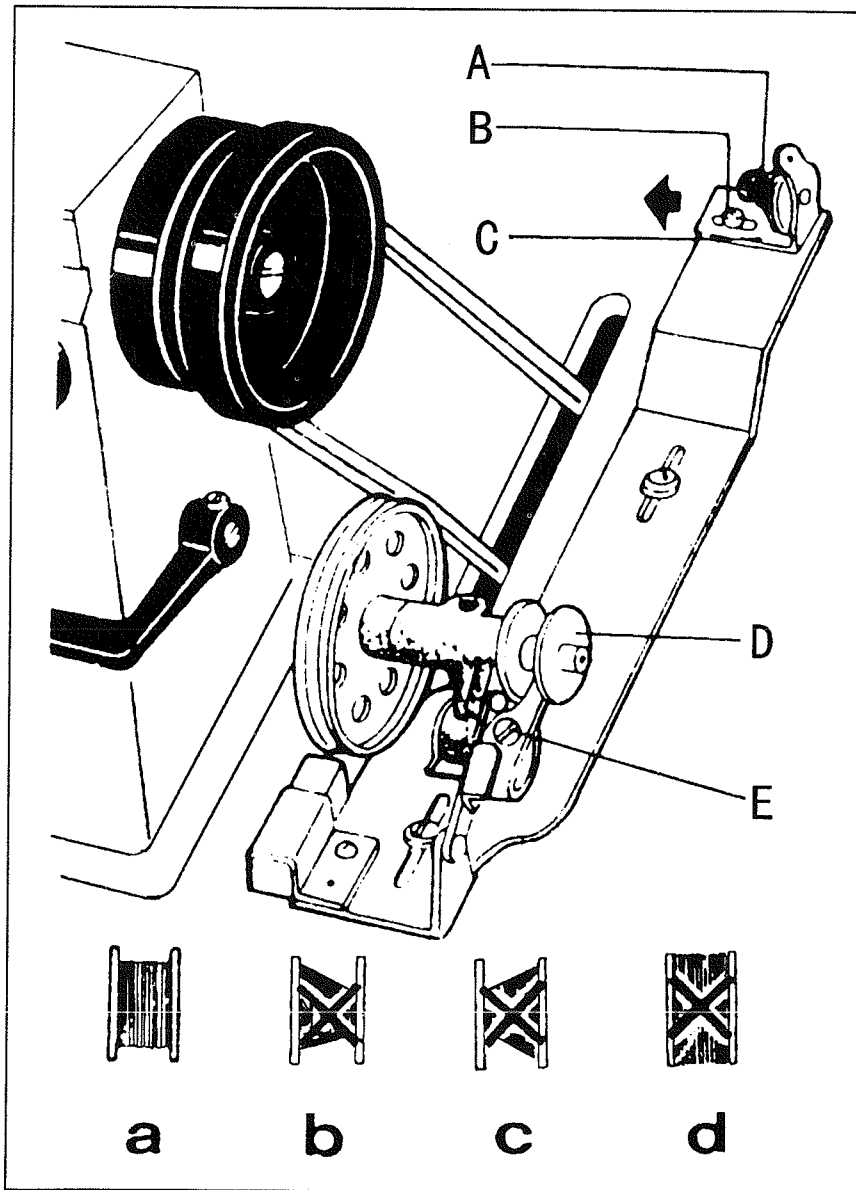

Fig. 8

10. SET STITCH LENGTH AND REVERSE FEEDING (Fig.9)

- 1) Stitch length can be set by turning Dial (A).
- 2) The figures on Face (B) of dial show stitch length in mm.
- 3) Reverse feeding starts when Reverse Feed Lever (C) is depressed, and the machine will feed forward again if Reverse Feed lever (C) is released.

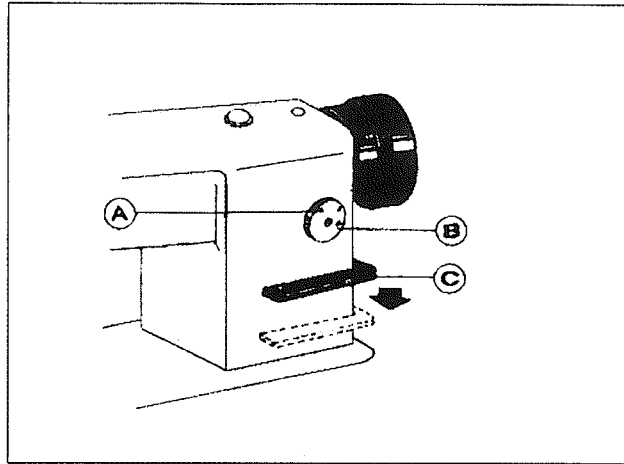

Fig. 9

11. POSITION PRESSER BAR (Fig.10)

- 1) Loosen lock Nut (E) and Pressure Regulating Thumb Screw (A).
- 2) Remove rubber plug from Face Plate (B).
- 3) Loosen Screw (C) and adjust the position of Presser Bar (D) till the presser foot is 6 mm above the throat plate will the presser foot lifted to its highest.
- 4) Tighten Screw (C) and put in the rubber plug.
- 5) Tighten pressure Regulating Thumb Screw (A) and Lock Nut (E).

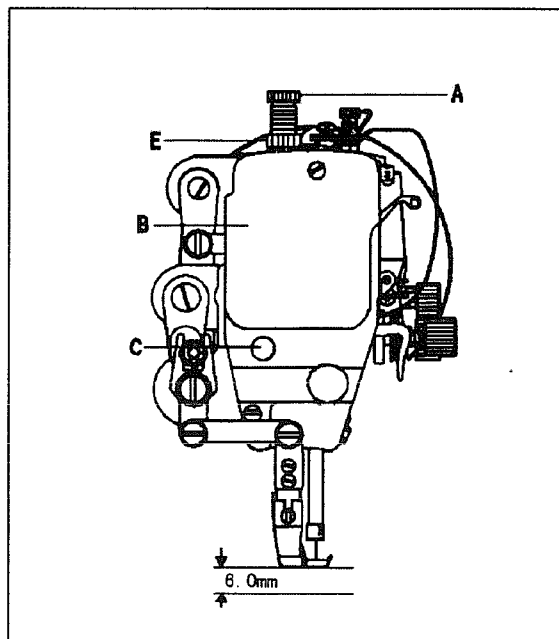

Fig. 10

12. ADJUST THE PRESSURE OF PRESSER FOOT (Fig.11)

Pressure of presser foot is to be adjust in accordance with thickness of materials to be sewn.

First loosen Lock Nut (A). For heavy materials, turn the pressure regulating thumb screw as shown in Fig.10 (a) to increase the pressure, while for light materials, turn the pressure regulating thumb screw as shown in Fig.10 (b) to decrease the pressure. Then tighten Lock Nut (A).

The pressure of presser foot is recommended to be less as long as normal feeding is ensured.

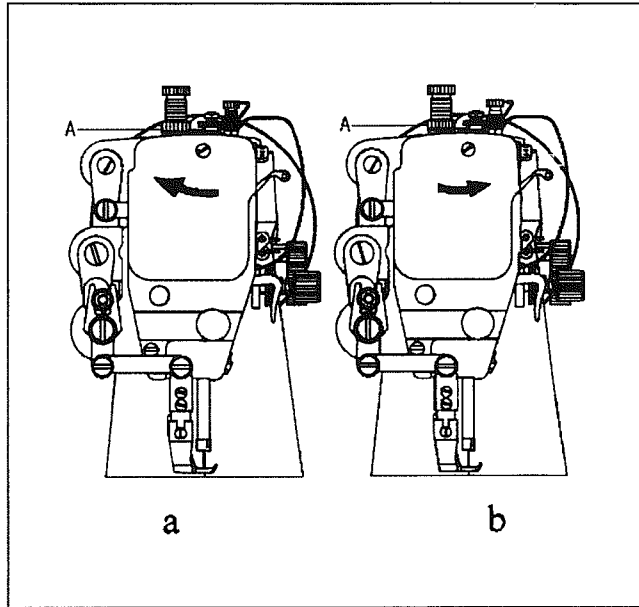

Fig. 11

13. ADJUST THREAD TENSION (Fig.12,13)

In principle, thread tension is to be adjusted in accordance with materials, thread and other factors.

In practice, thread tension is adjusted according to the stitches obtained. The needle thread tension should be adjusted with reference to the bobbin thread tension. Turn Tension Spring Regulating Screw (A) of bobbin case clockwise for more tension, or turn the screw counter-clockwise for less tension.

It is common practice to test the bobbin test the bobbin thread tension as shown in Fig.13 . Hold the end of the thread from delivery eye. If the bobbin case is falling slowly, the proper tension is obtained. The needle thread tension can be adjusted by setting (1) the take-up spring tension. (2) the thread take-up spring stroke and (3) tension spring. All these adjustments will be described in the following.

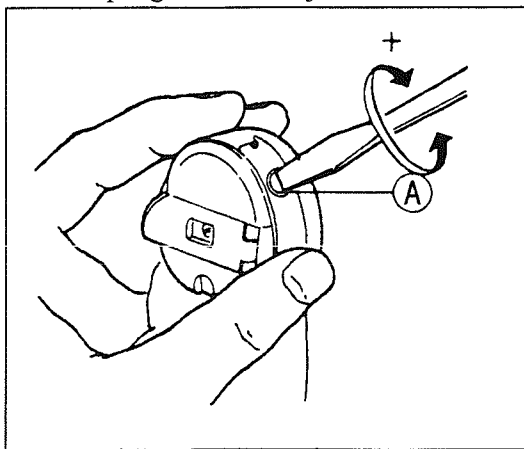

Fig. 12

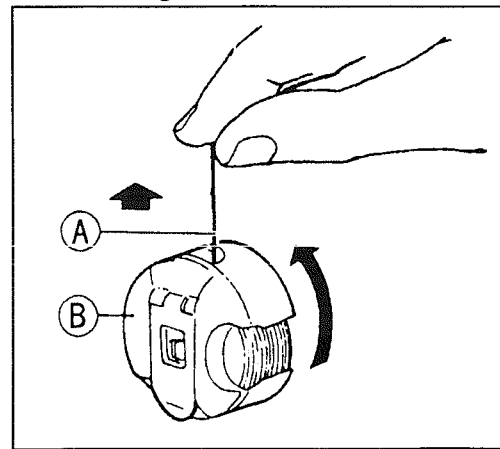

Fig. 13

14. ADJUST THREAD TAKE-UP SPRING (Fig.14,15)

1) Adjusting the thread take-up spring tension

Loosen Set Screw (A), turn Tension Stud (B) clockwise to increase the spring tension, or turn the stud counter-clockwise to decrease the spring tension. After the adjustment, be sure to tighten Set Screw (A). The thread take-up spring tension should be about 30g. To Attain this. First loosen Set Screw (A), turn Tension Stud (B) counter-clockwise to decrease the tension of Thread Take-up Spring (C) to zero, then turn Tension Stud (B) clockwise until Spring (C) comes to the notch of thread tension regulating bushing, and again turn Tension Stud (B) halfway back (counterclockwise) After the adjustment. Tighten Set Screw (A).

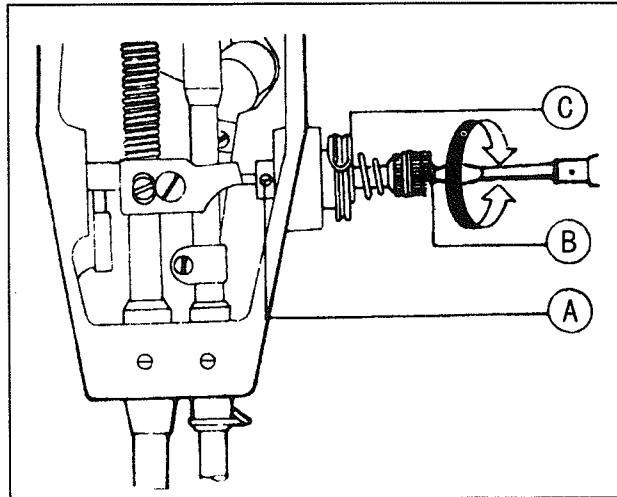

Fig. 14

2) Adjusting the thread take-up spring stroke

Loosen Set Screw (B), turn Stud (C) clockwise to increase the stroke or turn Stud (C) counter-clockwise to decrease the stroke. After the adjustment, tighten Set Screw (B).

Before leaving the factory, the thread take-up spring has properly been adjusted. Readjustment is needed only in the case of special material or special thread.

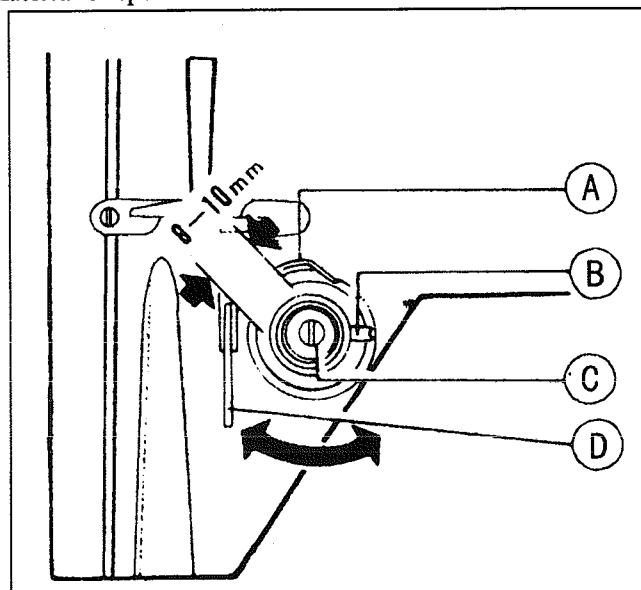

Fig. 15

15. ADJUST THREAD GUIDE AND THREAD TENSION (Fig.16,17)

The position of the thread guide affects stitch tightness and therefore must be adjusted according to sewing materials and sewing conditions.

	1	2	3
Thread guide position	Leftward	Center	Rightward
Material weight	Heavy	Medium	Light

Fig.15 shows different stitch forms. Normal stitch form should be as shown in Fig.15 (a). When abnormal stitches cause puckering and thread break-age, the tension of needle thread and bobbin thread must be adjusted accordingly.

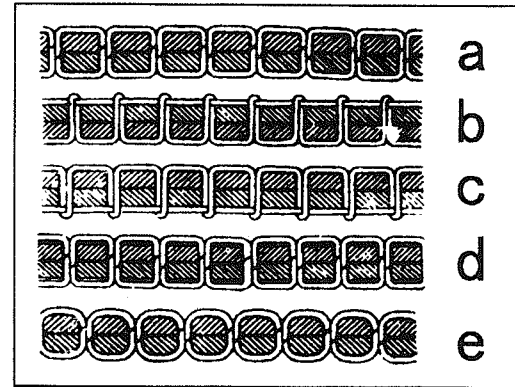

Fig. 16

- 1) In case needle thread tension is too strong or bobbin thread tension is too weak, as shown in Fig.15 (b), turn the thumb nut counterclockwise to decrease the needle thread tension, or tighten the tension spring regulating screw of bobbin case to increase the bobbin thread tension (See Fig.16)
- 2) In case needle thread tension is too weak or bobbin thread tension is too strong, as shown in Fig.15 (c), turn the thumb nut clockwise to increase the needle thread tension, or loosen the tension spring regulating screw of bobbin case to decrease the bobbin thread tension.
- 3) In case of the stitch forms as shown in Fig.15 (d) and (e), adjustments can be made with reference to the above means.

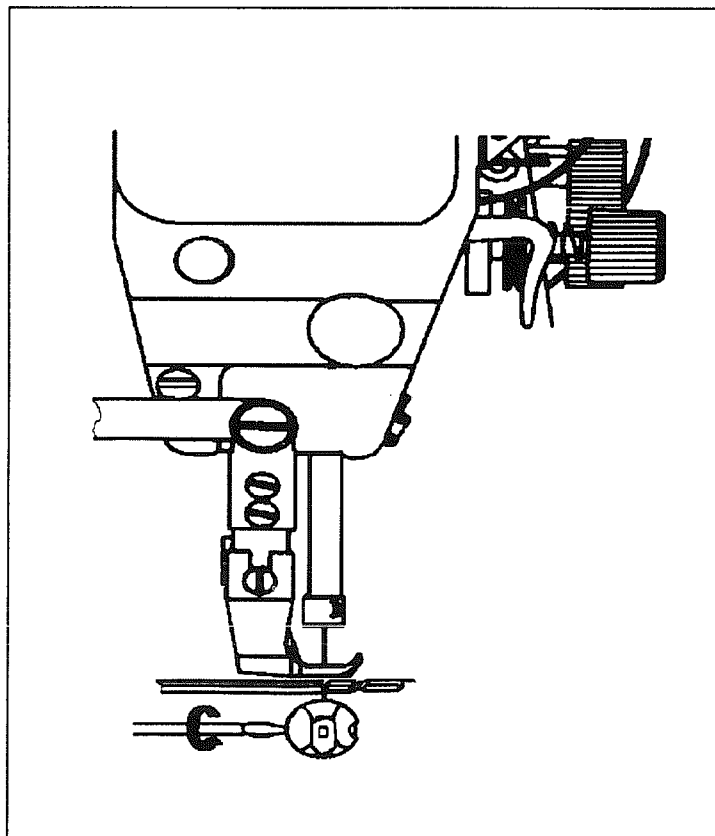

Fig. 17

16. TIME NEEDLE TO ROTAING HOOK (Fig.18,19,20,21)

A. Adjusting the needle position (See Fig.18)

- 1) Turn balance wheel by hand to bring Needle Bar (C) to the lowest position of its stroke.
- 2) Remove rubber plug from Face Plate (A).
- 3) Loosen Set Screw (B) of needle bar adaptor.
- 4) Move Needle Bar (C) vertically to adjust needle timing.
- 5) After the adjustment, tighten Set Screw (B) and put in the rubber plug. The standard needle timing (See Fig.18) is to align Timing Mark (B) on the needle bar and the bottom of Needle Bar Bushing (A) and meanwhile align the Inner Surface (E) of the hook and the center of Needle Eye (D) when the needle bar gets down to its lowest position.

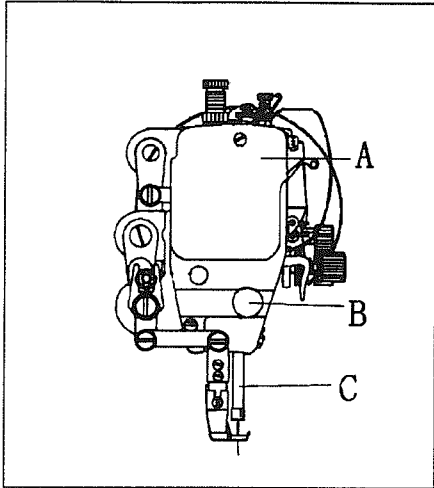

Fig. 18

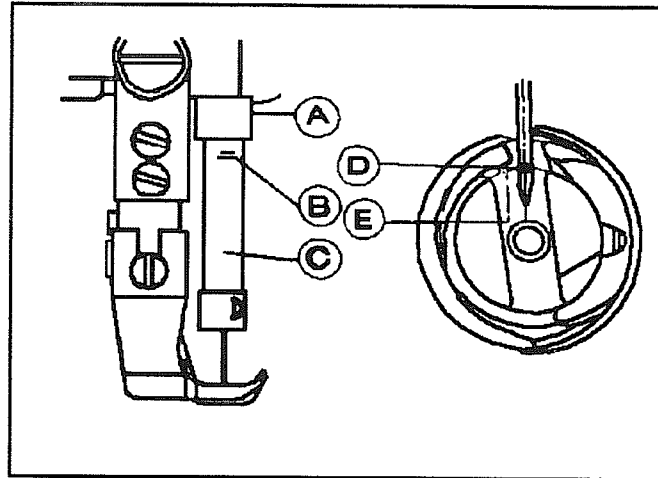

Fig. 19

B. Adjusting the hook point timing

Timing of needle motion to rotating hook motion has a great effect on sewing performance. The standard hook point timing (See Fig.20) is to align Hook Point (D) and Needle Centerline (C) when Needle Bar (B) is lifted by 2.2mm from the lower end of its stroke. Besides, Hook Point (D) should be 1.0-1.5mm above the upper end of needle eye (E).

When adjusting the hook point timing, also notice that the clearance between the bottom of needle notch and Hook Point (C) should be approx. 0.05mm (See Fig.21)

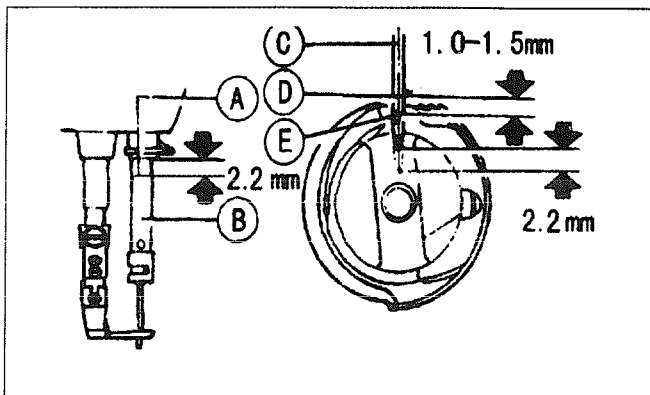

Fig. 20



图 21

17. REPLACE ROTATING HOOK (Fig.22)

- 1) Lift needle bar to the highest position of its stroke.
- 2) Remove throat plate, take down needle and bobbin case.
- 3) Loosen Screw (C) of hook positioner and take down Hook Positioner (A).
- 4) Loosen two Screws (D) of rotating hook.
- 5) Turn balance wheel to raise feed bar to its highest position, then take down the rotating hook by turning it away from feed bar.
- 6) Installing the hook can be done in reverse sequence. Note that Needle (B) and the convex surface of Hook Positioner (A) should align with a clearance of 0.5-0.7mm between them.

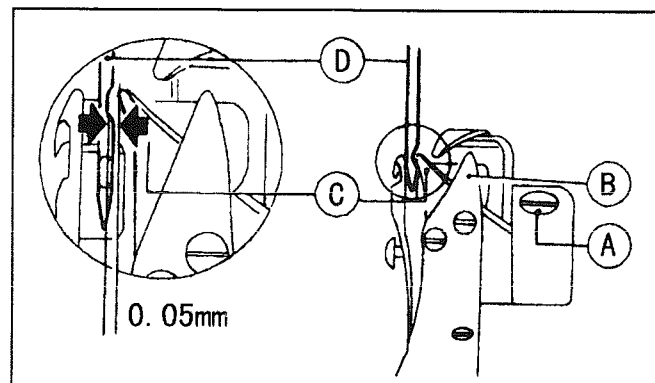
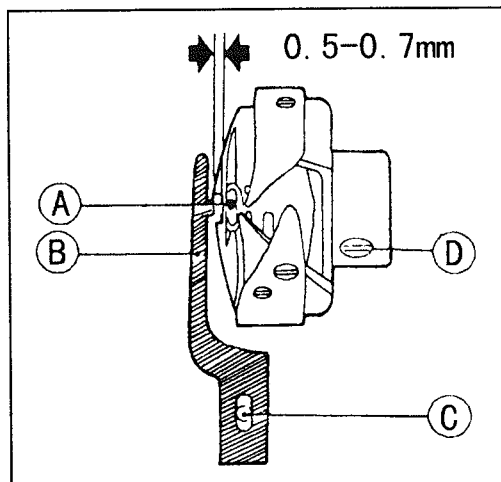

Fig. 22

18. ADJUST THE HEIGHT OF FEED DOG (Fig.23,24)

- 1) Turn balance wheel until feed dog is lifted to its highest position from throat plate surface.
- 2) Loosen Screw (A) of feed lifting rock shaft crank right (See Fig.23,b)
- 3) Move Feed Bar (B) in the direction shown by the arrow in Fig. 23 (a) to adjust the height of the feed dog. The standard height of feed dog is that the top of feed dog is 1mm above Throat Plate Surface (B).
- 4) After the adjustment, be sure to tighten Screw (A).

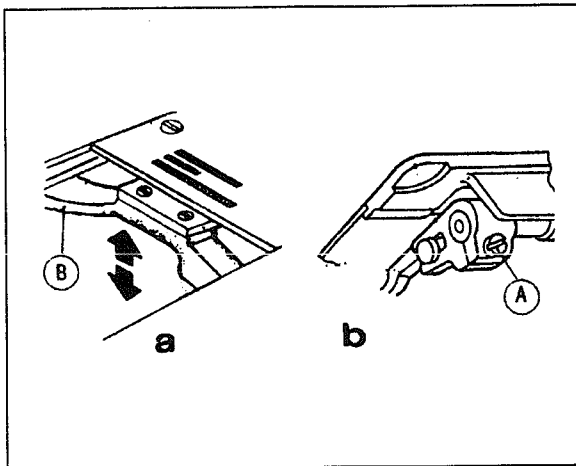

Fig. 23

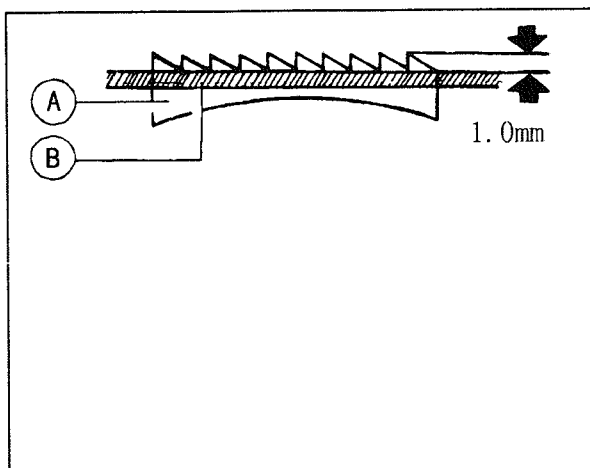

Fig. 24

19. Adjustment of feed dog inclination (Fig.25,26):

If necessary, adjust the inclination according to the material to be sewn as follows:

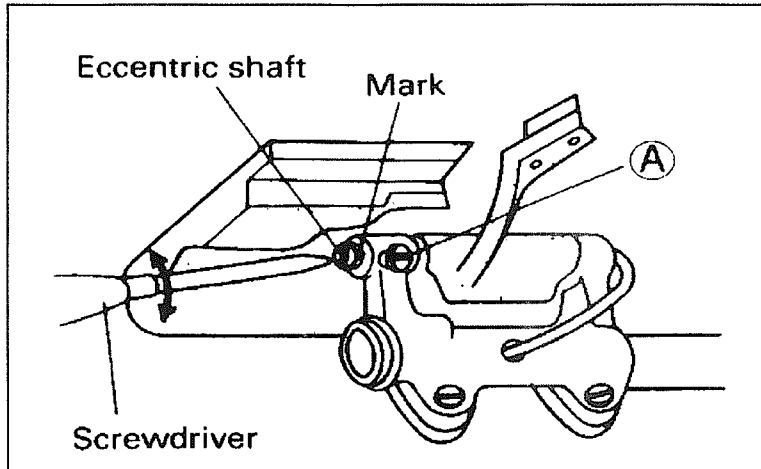

Fig. 25

- 1) Loosen the screw "A".
- 2) Rotate the eccentric shaft clockwise or counterclockwise with screw driver.
- 3) Tighten the screw "A".







Position of mark on the eccentric shaft	Feed dog
 Horizontal	 Standard
 Up	 Front up (MAX.)
 Down	 Front down (MAX.)

Fig. 26

20. TIME FEED MOTION TO NEEDLE MOTION (Fig.27,28,29)

The standard timing of feed motion to needle motion is that the top of feed Dog (C) is flush with Throat Plate Surface (B) when the point of Needle (A) reaches Throat Plate Surface (B). See Fig.27 .

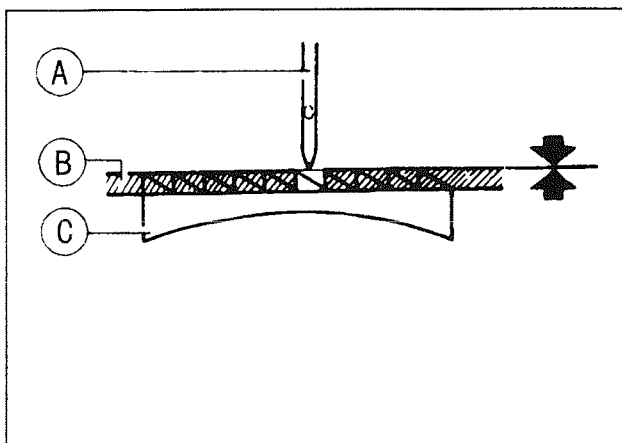

Fig. 27

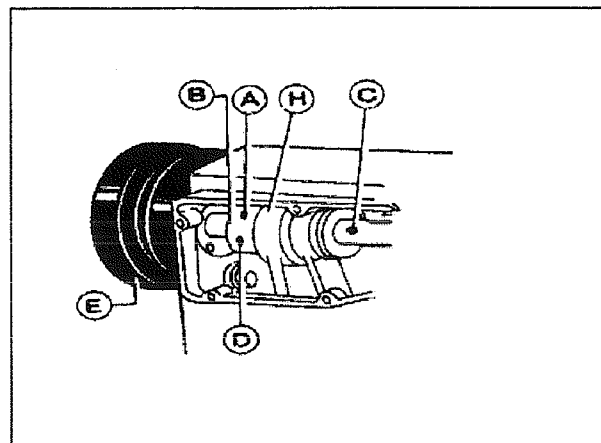

Fig. 28

If feed motion is not timed to needle motion, adjust as follows (See Figs.28 and 29).

- 1) Remove Arm Side Cover .
- 2) Loosen Set Screws (A) and (D) of feed and feed lifting eccentric.
- 3) Hold Feed and Feed Lifting Eccentric (B) and turn Balance Wheel (E) slowly until the upper edge of Arm Shaft Oil Hole (C) aligns with the lower edge of Reference Hole (G) of feed and feed lifting eccentric.

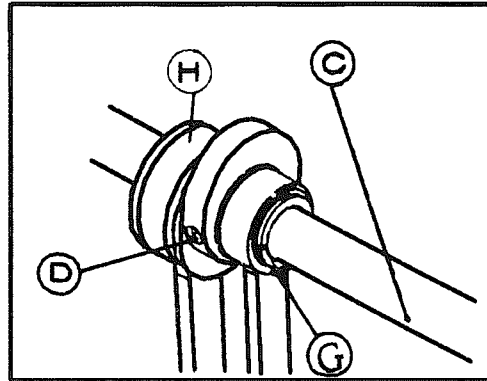

Fig. 29

21. ADJUST OPENING TIME OF THE TENSION DISCS (Fig.30)

within the presser foot lift range of 2-7mm opening time of the tension discs can be adjusted as follows:

- 1) Remove the rubber plug from the back of arm and loosen Screw (A) of knee lifter lever (left).
- 2) Move the tension releasing cam leftward for earlier opening or rightward for later opening. It will facilitate the adjustment to put under the presser foot a block as thick as the presser foot lift.
- 3) After the adjustment, fully tighten Screw (A).

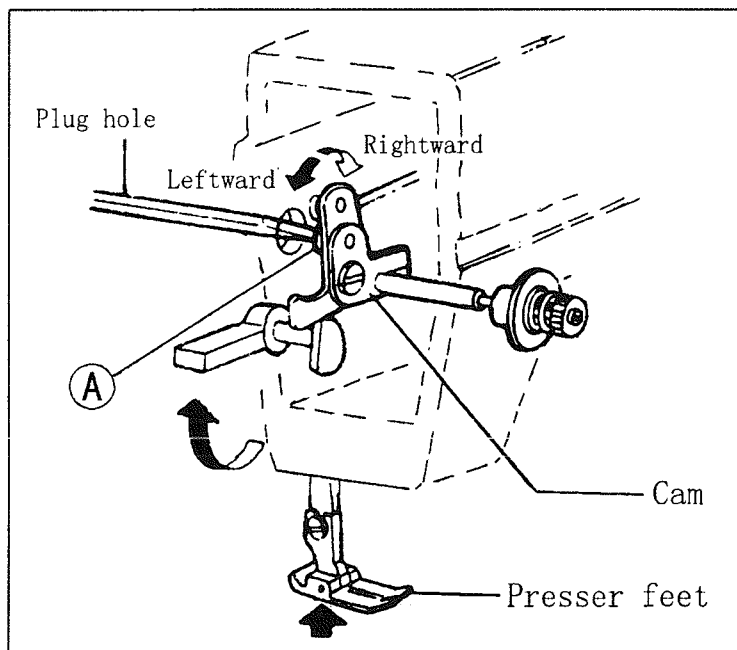

Fig. 30

22. LUBRICATION ADJUSTMENT (Fig.31)

A. Adjusting oil pump.

In ordinary operation, adjustment is not required for the oil pump. If oil splashing does not occur in the oil check window when the machine runs at a low, speed (approx.2000spm), reduce the clearance of the by-pass hole.

B. Adjusting the lubrication of rotating hook.

The lubrication of the rotating hook can be adjusted by Oil Adjusting Screw (A) as follows:

1) Turn Oil Adjusting Screw (A) clockwise to increase oil and turn Oil Adjusting Screw (A) counterclockwise to decrease oil.

2) Oil Adjusting Screw (A) adjusts oil amount within 5 turns. When Oil Adjusting Screw (A) is fully tightened, oil amount is maximum.

3) Readjustment depends on temperature, sewing speed and the like. In practice, oil amount can be judged as follows: remove the throat plate and place a piece of paper on instead, run the machine for about 20 seconds, then check the oil splashed on the paper.

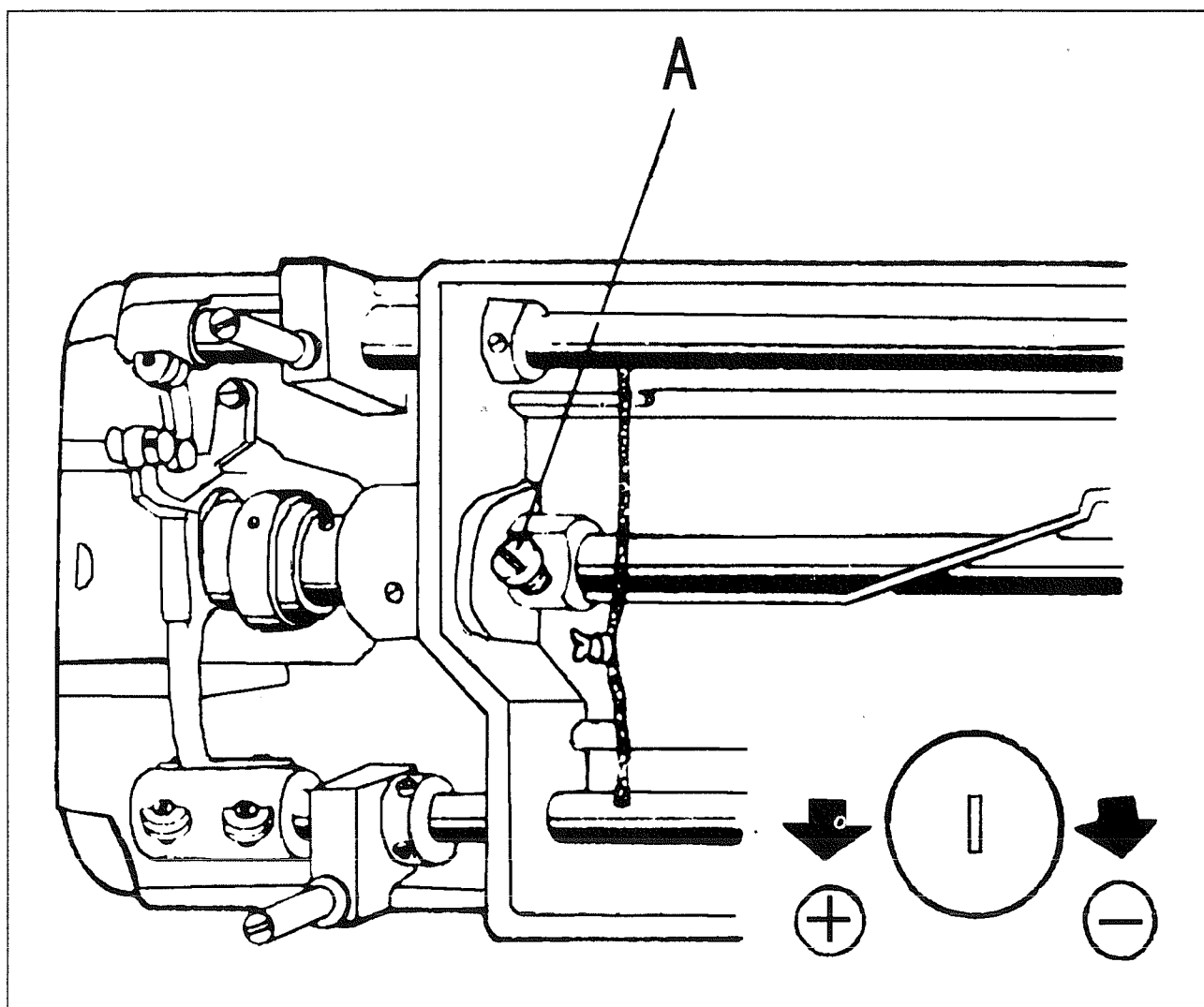

Fig. 31

23. REGULAR CLEANING (Fig.32,33,34)

1) Cleaning feed dog (See Fig.32)

Remove the throat plate and clear off the dust and lint between feed dog tooth slots.

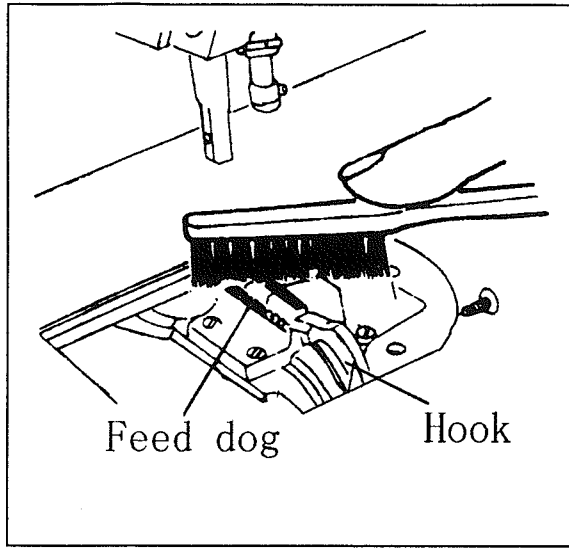

Fig. 32

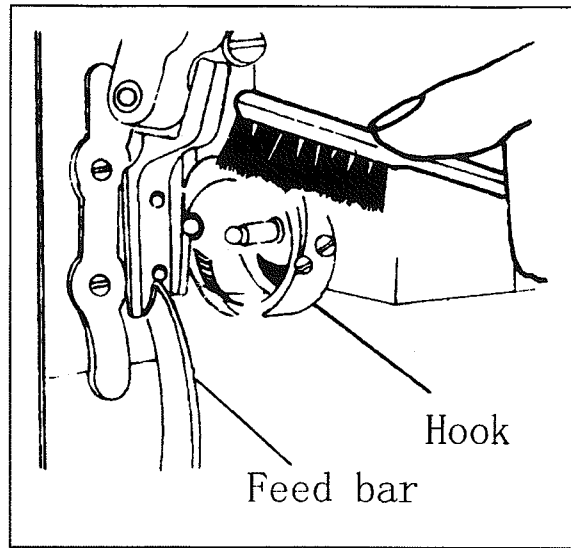

Fig. 33

2) Cleaning rotating hook (See Fig 33)

Swing out the machine head and clean the hook. Wipe the bobbin case with soft cloth.

3) Cleaning oil pump, screen (See Fig.34)

Swing out the machine head and clear off the dust and dirt on oil pump screen.

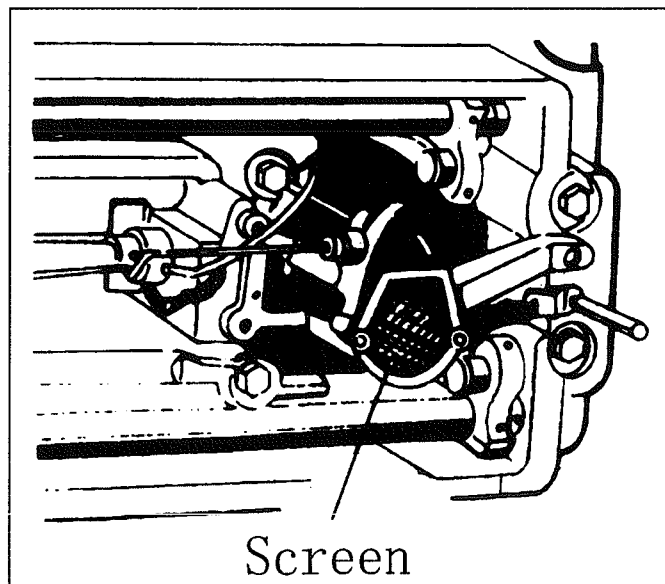
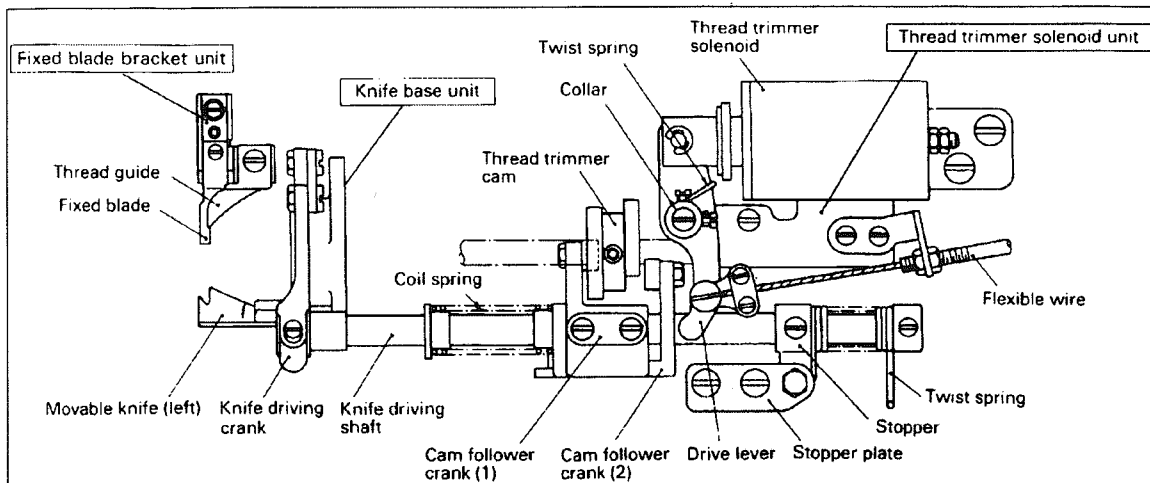

Fig. 33

24、 Adjustment of thread trimmer mechanism:

1) The thread trimmer mechanism illustrated as Fig.35.



(1) Operation stroke of the thread trimmer solenoid:

- a. Standard operation stroke is 6.0mm.
- b. This stroke can be adjusted by using nut "A".

2) Adjustment of knife engagement (Fig.36):

(1) Position of movable knife (left) and fixed blade:

See the Fig.36, the standard distances from the needle center are 7.5mm and 5mm from the movable knife (left) and fixed blade respectively.

(2) Adjustment of knife engagement:

With the solenoid activated, turn on the machine. This rotates the threadtrimming cam which rotates the movable knife (left). When the movable knife (left) has moved to its farthest distance, the standard engagement of the blade is 1.5mm-2.0mm. The engagement can be adjusted by properly mounting the drive arm.

(3) Adjustment of knife engagement pressure:

a. If a thread is poorly cut, particularly when it is thick, slightly increase the engaging pressure. This should solve the problem.

b. The engaging pressure can be adjusted in this way:

Loosen lock nut "B" and adjust it by using adjusting screw "A"

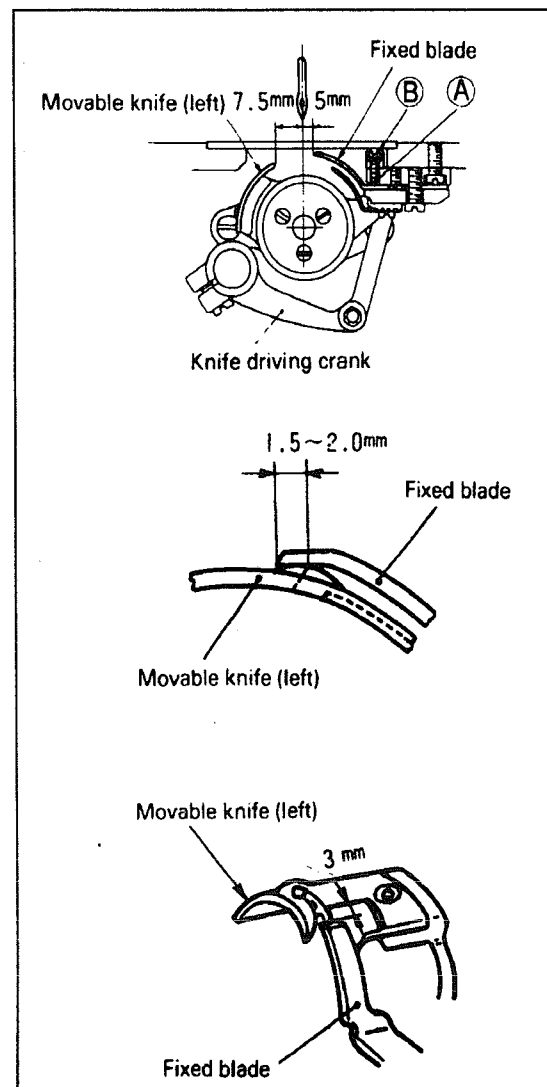
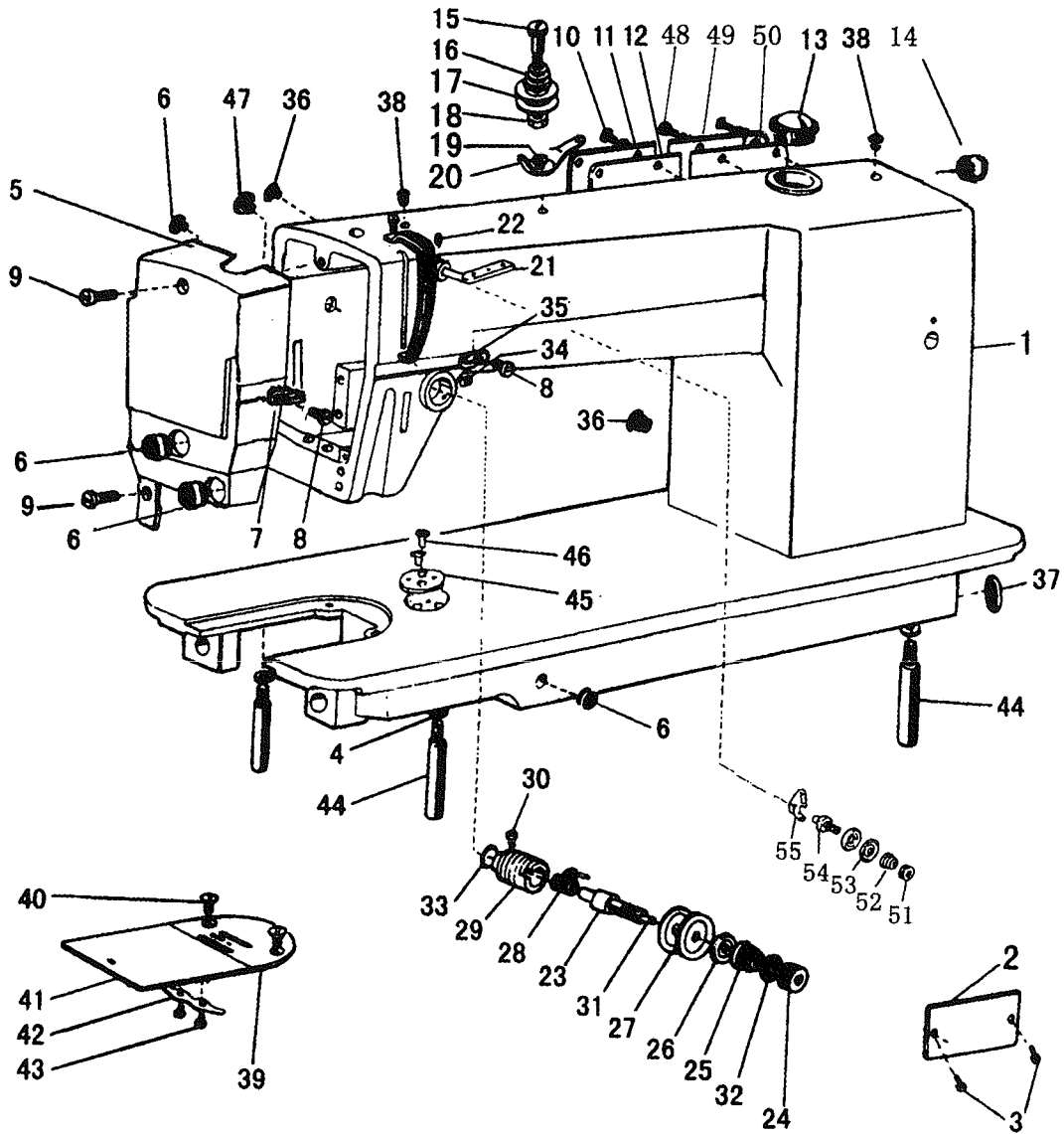

Fig. 36

A. ARM BED AND ITS ACCESSORIES



A.ARM BED AND ITS ACCESSORIES

Fig. No.	Part No.	Description	GC0318-2A	GC0318-2H	GC0318-2B	GC0318-2AD	Remarks
A01	HM307B8001	Arm	1		1		
A01	HN208B8001	Arm		1			
A01	HN606B8001	Arm				1	
A02	HM309B8001	Trade mark plate	1				
A02	HN408B8001	Trade mark plate		1			
A02	HN305B8001	Trade mark plate			1		
A02	HN608B8001	Trade mark plate				1	
A03	H924025050	rivet	6	6	6	6	GB/T827 $\phi 2.5 \times 5$
A04	H005008060	Spring washer	2	2	2	2	GB/T93 6
A05	H2005B0065	Face plate	1	1	1	1	
A06	HA306B0674	Rubber plug ($\phi 11.8$)	3	3	3	3	
A07	HA607B0671	Thread guide on face plate	1	1	1	1	
A08	HA106B0676	Thread guide screw	1	1	1	1	SM9/64 (40) $\times 6$
A09	HA700B2030	Face plate screw	2	2	2	2	SM11/64 (40) $\times 20$
A10	HA300B2170	Screw group	4	4	4	4	
A11	H6028B8001	Arm side cover	1	1	1	1	
A12	H6029B8001	Gasket for arm side cover	1	1	1	1	
A13	H1210B0671	Check window	1	1	1	1	
A14	H6030B8001	Rubber plug ($\phi 22$)	1	1	1	1	
A15	HA112B0691	Screw type tension stud	1	1	1	1	SM11/64 (40) $\times 16$
A16	HA112B0692	Spring for pre-tension	1	1	1	1	
A17	HA112B0693	Disc for pre-tension	2	2	2	2	
A18	HA112B0694	Spacer for pre-tension	1	1	1	1	
A19	H007013030	Stop ring	1	1	1	1	GB/T896 3
A20	HA112B0695	Pre-tension thread guide	1	1	1	1	
A21	HA100B2100	Three-hple thread guide	1	1	1	1	
A22	HA100B2110	Set screw	1	1	1	1	SM11/64 (40) $\times 5.5$
A23	HA115B0701	Thread tension stud	1	1	1	1	SM1/4 (40) $\times 17$
A24	HA310B0701	Oil thumb nut	1	1	1	1	
A25	HA505B0671	Thread tension spring	1	1	1	1	
A26	HA310B0702	Thread tension releasing disc	1	1	1	1	
A27	HA310B0705	Thread tension disc	2	2	2	2	
A28	HA505B0672	Thread take-up spring	1	1	1	1	
A29	HA310B0703	Thread tension regulating bushing	1	1	1	1	
A30	HA115B0708	Set screw	1	1	1	1	SM9/64 (40) $\times 4$
A31	HA115B0709	Thread tension releasing pin	1	1	1	1	
A32	HA115B7010	Stop disc	1	1	1	1	
A33	HA115B7011	Rubber ring	1	1	1	1	
A34	HA300B2080	Set screw	1	1	1	1	SM15/64 (28) $\times 6.8$
A35	HA600B2050	Thread guide at arm center	1	1	1	1	
A36	HA300B2090	Rubber plug ($\phi 8.8$)	2	2	2	2	
A37	HA300B2100	Rubber plug ($\phi 27$)	1	1	1	1	
A38	HA300B2110	Red rubber plug ($\phi 5.7$)	2	2	2	2	

A.ARM BED AND ITS ACCESSORIES

Fig. No.	Part No.	Description	GC0318-2A	GC0318-2H	GC0318-2B	GC0318-2AD	Remarks
A39	H2100B2120	Needle plate	1			1	
A39	HN208B8001	Needle plate		1			
A39	H6520B8001	Needle plate			1		
A40	HA300B2190	Needle plate screw	2	2	2	2	SM11/64(40)×4.5
A41	HA124B0711	Slide plate	1	1	1	1	
A42	HA124B0712	Slide plate spring	1	1	1	1	
A43	HA124B0713	Screw	2	2	2	2	SM3/32(56)×2.2
A44	HA100B2220	Leg	3	3	3	3	
A45	HA300B2140	Plate for guide	1	1	1	1	
A46	HA300B2130	Screw	2	2	2	2	SM11/64(40)×5
A47	HA307B0673	Rubber plug	1	1	1	1	
A48	HA300B2160	Screw	5	5	5		
A49	H6409B8001	Arm bed cover	1	1	1		
A50	H6410B8001	Gasket for arm bed cover	1	1	1		
A51	HA710B0671	Nut				1	
A52	HA710B0672	Spring for pre-tension				1	
A53	HA112B0692	Disc for pre-tension				2	
A54	HA710B0673	Screw				1	
A55	HA710B0674	Pre-tension thread guide				1	

B. NEEDLE BAR AND TAKE-UP LEVER, ARM SHAFT MECHANISM

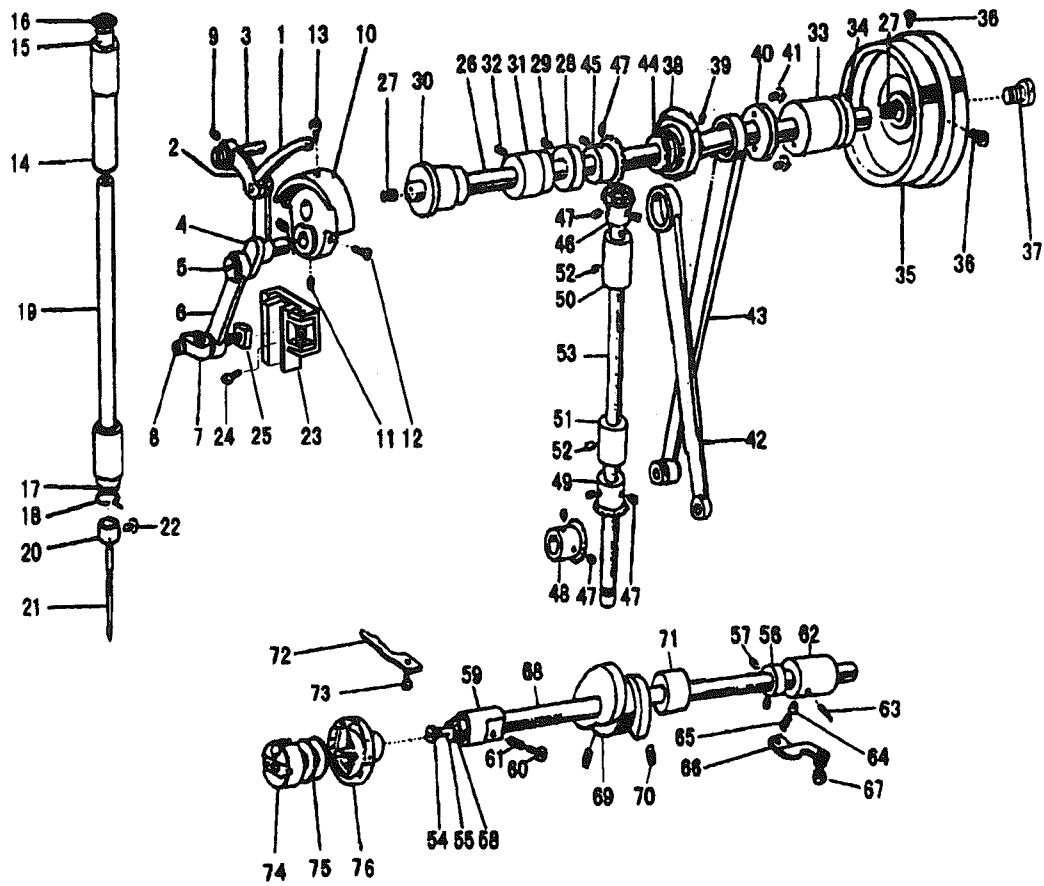

B.NEEDLE BAR AND TAKE-UP LEVER, ARM SHAFT MECHANISM

Fig. No.	Part No.	Description	GC0318-2A	GC0318-2H	GC0318-2B	GC0318-2AD	Remarks
B01	H1111C204	Therad take-up lever	1		1	1	
B01	HA311C104	Therad take-up lever		1			
B02	H11112C104	Thread take-up lever link	1		1	1	
B02	HA304C0012	Thread take-up lever link		1			
B03	HA104C0653	Hinge pin	1	1	1	1	
B04	HA504C0651	Thread take-up crank	1	1	1	1	
B04	HA104C0655	Needle bearing	2	2	2	2	
B05	HA104C0656	Set screw (left-handed)	1	1	1	1	SM9/64 (40) × 7
B06	HA304C0653	Needlc bar link	1	1	1	1	
B07	HA104C0658	Needle bar adaptor	1	1	1	1	
B08	HA104C0659	Screw	1	1	1	1	SM9/64 (40) × 6
B09	HA100C2020	Set screw	1	1	1	1	SM15/64 (28) × 10
B10	HA307C0661	Needle bar crank	1	1	1	1	
B11	HA307C0662	Set screw	2	2	2	2	SM1/4 (40) × 6
B12	HA100C2060	Set screw	1	1	1	1	SM9/32 (28) × 13
B13	HA100C2070	Set screw	1	1	1	1	SM9/32/ (28) × 14
B14	HA100C2080	Needle bar bushing (upper)	1	1	1	1	
B15	HA100C2100	Felt plug	1	1	1	1	
B16	HA300C2050	Red rubber plug (φ 8.8)	1	1	1	1	
B17	HA804B0652	Needle bar bushing (lower)	1	1	1	1	
B18	HA500C2060	Thread guide for needle bar bushing	1	1	1	1	
B19	H2100C2010	Needle bar	1		1	1	
B19	HA700G2030	Needle bar		1			
B20	HA500C2030	Thread guide for needle bar	1	1	1	1	
B21	H2000G2030	Needle	1			1	DP × 17 22#
B21	HA700G2040	Needle		1			DP × 5 14#
B21	H6524B8001	Needle			1		DP × 17 25#
B22	HA100C2170	Needle clamp screw	1	1	1	1	SM1/8 (44) × 4.5
B23	HA100C2180	Guide for slide block	1	1	1		
B23	HA704G0065	Guide for slide block complete				1	
B24	HA100C2190	Set screw	2	2	2	2	SM11/64 (40) × 8
B25	HA100C2200	Slide block	1	1	1	1	
B26	H2604C0651	Arm shaft	1	1	1	1	
B27	HA104D0652	Rubber plug (φ 7.4 × 10)	2	2	2	2	
B28	HA108G0661	Collar for	1	1	1	1	
B29	HA105D0662	Set screw	2	2	2	2	SM1/4 (40) × 4
B30	HA100D2030	Arm shaft bushing(left)	1	1	1	1	
B31	HA100D2040	Arln shaft bushing(middle)	1	1	1	1	
B32	HA100C2020	Set screw	1	1	1	1	SM15/64 (28) × 10
B33	HA300D2020	Arvn shaft bushing(right)	1	1	1	1	
B34	HA306D0066	Oil seal	1	1	1	1	
B35	H2000C2040	Balance wheel	1	1	1	1	
B36	HA110D0672	Set screw	2	2	2	2	SM15/64 (28) × 12

B.NEEDLE BAR AND TAKE-UP LEVER, ARM SHAFT MECHANISM

Fig. No.	Part No.	Description	GC0318-2A	GC0318-2H	GC0318-2B	GC0318-2AD	Remarks
B37	HA100D2080	Screw	1	1	1	1	SM11/32 (28) × 10
B38	H6510D8001	Feed and feed lifting eccentric	1		1	1	
B38	HA7311C106	Feed and feed lifting eccentric		1			SM15/54 (28) × 7
B39	HA100C2020	Set screw	2	2	2	2	
B40	H6511D8001	Feed cam cover	1		1	1	82T2-003C1a1
B40	HA7311C206	Feed cam cover		1			
B41	HA7311C306	Set screw	3	3	3	3	
B42	HA112D3013	Crank rod for feed lifting rock shaft	1	1	1	1	
B43	HA7311C506	Feed rock	1	1	1	1	
B44	HA112D3012	stop ring	1	1	1	1	
B45	HA113D2112	Bevel gear for arm shaft	1	1	1	1	
B46	HA113D2122	Bevel gear for vertical shaft(upper)	1	1	1	1	
B47	HA108C0663	Set screw	8	8	8	8	SM1/4 (40) × 7
B48	HA113D2212	Bevel gear for hook shaft	1	1	1	1	
B49	HA113D2222	Bevel gear for vertical shaft(lower)	1	1	1	1	
B50	HA100D2110	Vertical shaft bushing(upper)	1	1	1	1	
B51	HA600D2010	Vertical shaft bushing(lower)	1	1	1	1	
B52	HA100C2020	Set screw	2	2	2	2	SM15/64 (28) × 10
B53	H2100D2010	Vertical shaft	1	1	1	1	
B54	HA1111E104	Filter screw	1	1	1	1	SM3/16 (32) × 9
B55	HA1111E204	Filter	1	1	1	1	
B56	HA305E0661	Collar for hook shaft	1	1	1	1	
B57	HA305E0662	Set screw	2	2	2	2	SM15/64 (28) × 4.5
B58	HA106E0071	Oil seal for rotating hook shaft	1	1	1	1	
B59	HA100E2040	Hook shaft bushing (left)	1	1	1	1	
B60	HA100E2050	Oil adjusting screw	1	1	1	1	SM11/64 (40) × 28.5
B61	HA100E2060	Spring for oil adjuster	1	1	1	1	
B62	HA311E0671	Hook shaft bushing (right)	1	1	1	1	
B63	HA110E0672	Oil pipe for hook shaft bushing	1	1	1	1	
B64	HA300E2100	Plunger	1	1	1	1	
B65	HA300E2110	Plunger spring	1	1	1	1	
B66	HA600E2020	Guide plate	1	1	1	1	
B67	HA104F0654	Screw	1	1	1	1	SM15/64 (28) × 10
B68	HA604E0651	Hook shaft	1	1	1	1	
B69	HA710E0691	cam				1	
B70	HA710E0692	Screw				2	
B71	HA704B0653	Hook shaft bushing	1	1	1	1	
B72	H2100E2010	Rotating hook positioner	1		1	1	
B72	HA300E2050	Rotating hook positioner		1			
B73	HA100E2150	Screw	1	1	1	1	SM11/64 (40) × 13
B74	HA608E0067	Bobbin case	1		1		
B74	HA300E2070	Bobbin case		1			
B74	HA900E2030	Bobbin case				1	

B.NEEDLE BAR AND TAKE-UP LEVER, ARM SHAFT MECHANISM

Fig. No.	Part No.	Description	GC0318-2A	GC0318-2H	GC0318-2B	GC0318-2AD	Remarks
B75	H1100E2010	Bobbin	1		1		
B75	HA100E2170	Bobbin		1			
B75	HA900E2030	Bobbin				1	
B76	H1105E0066	Rotating hook complete	1				
B76	HA500E2030	Rotating hook complete		1			
B76	H6519B8001	Rotating hook complete			1		
B76	HA906E0066	Rotating hook complete				1	

C. STITCH REGULATOR MECHANISM

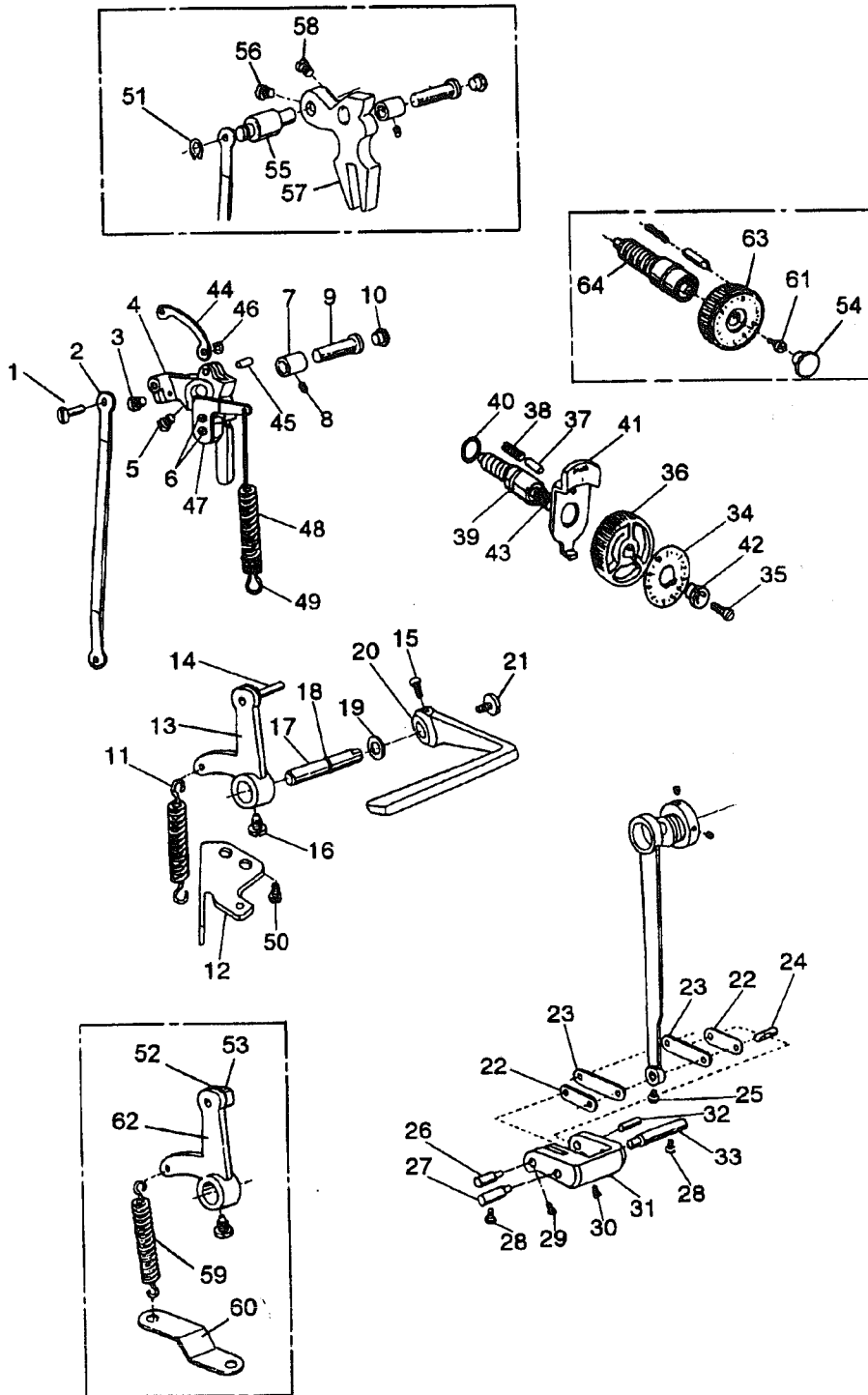

C.STITCH REGULATOR MECHANISM

Fig. No.	Part No.	Description	GC0318-2A	GC0318-2H	GC0318-2B	GC0318-2AD	Remarks
C01	HA700C2060	Pin				1	
C02	HA7311C406	Connecting rod stud				1	
C03	HA111G0683	Screw	1	1	1	1	
C04	HB5251F081	Feed regulator				1	
C05	HA113F0684	Screw				1	
C06	HA100C2190	Screw				2	
C07	HA704B0655	Bushing for feed regulator	1	1	1	1	
C08	HA100C2020	Screw	1	1	1	1	
C09	HA100F2040	Pin	1	1	1	1	
C10	HA700B2120	Rnbber plug	1	1	1	1	
C11	H2600E2050	Spring				1	
C12	HA800F2010	Bracket spring				1	
C13	H2605E0661	Reverse feed crank				1	
C14	H2207D0671	Slide block pin				1	
C15	HA104F0654	Screw	2	2	2	2	
C16	HA100F2130	Screw	1	1	1	1	
C17	HA113F3021	Reverse feed lever shaft	1	1	1	1	
C18	HA113F3022	O-ring	1	1	1	1	
C19	HA100F2110	Washer	1	1	1	1	
C20	HA309F0671	Reverse feed lever	1	1	1	1	
C21	HA113F0683	Screw	1	1	1	1	
C22	HA706C1191	link (short)	2	2	2	2	
C23	HA8211C305	Link (long)	2	2	2	2	
C24	HA706C11B1	Link stud	1	1	1	1	
C25	HA7311C806	Screw	1	1	1	1	
C26	HA7311CF06	Link stud	1	1	1	1	
C27	HA700C2050	Feed regulator shaft (left)	1	1	1	1	
C28	HA111G0683	Screw	2	2	2	2	
C29	HA7311CC06	Screw	1	1	1	1	
C30	HA7311CD06	Screw	1	1	1	1	
C31	HA7311CG06	Stitch length adjusting crank	1	1	1	1	
C32	HA7311CE06	Link stud	1	1	1	1	
C33	HA700C2040	Feed regulator shaft (right)	1	1	1	1	
C34	HM308F8001	Plate for stitch length	1		1		
C34	HB5253F081	Plate for stitch length				1	
C35	HA720F0686	Screw	1		1	1	
C36	HA7421F120	Dial	1		1	1	
C37	HA100F2080	Stopper pin	1	1	1	1	
C38	HA100F2090	Spring for stopper pin	1	1	1	1	
C39	HA720F0681	Screw bar	1		1	1	
C40	HA109F0674	O-ring	1	1	1	1	
C41	HA720F0683	Stopper pin releasing lever	1		1	1	
C42	HA720F0685	Bushing	1		1	1	

C.STITCH REGULATOR MECHANISM

Fig. No.	Part No.	Description	GC0318-2A	GC0318-2H	GC0318-2B	GC0318-2AD	Remarks
C43	HA720F0687	Coil spring	1		1	1	
C44	HB5255F081	Reverse link				1	
C45	H2204D0652	Pin				1	
C46	H007013040	Stop ring				1	
C47	H2204D0653	Spring retainer				1	
C48	HA806C0674	Spring				1	
C49	HA806C0675	Spring retainer				1	
C50	HA800F2020	Screw				1	
C51	50	Stop ring	1	1	1		
C52	HA1511F115	shaft	1	1	1		
C53	HA1511F215	Slide block	1	1	1		
C54	HA300F2050	Rubber piug		1			
C55	H1204E0652	Stitch length adjusting swing shaft	1	1	1		
C56	HA100C2190	Screw	1	1	1		
C57	H1404E0651	Feed regulator	1		1		
C57	H1204E0651	Feed regulator		1			
C58	HA104F0654	Screw	1	1	1		
C59	HA115F0692	Spring	1	1	1		
C60	HA100F2140	Spring holder	1	1	1		
C61	HA109F0673	Screw		1			
C62	HA115F0691	Crank	1	1	1		
C63	H1205E0661	Dial		1			
C64	HA109F0671	Screw bar		1			

D. FEEDING AND FEED LIFTING MECHANISM

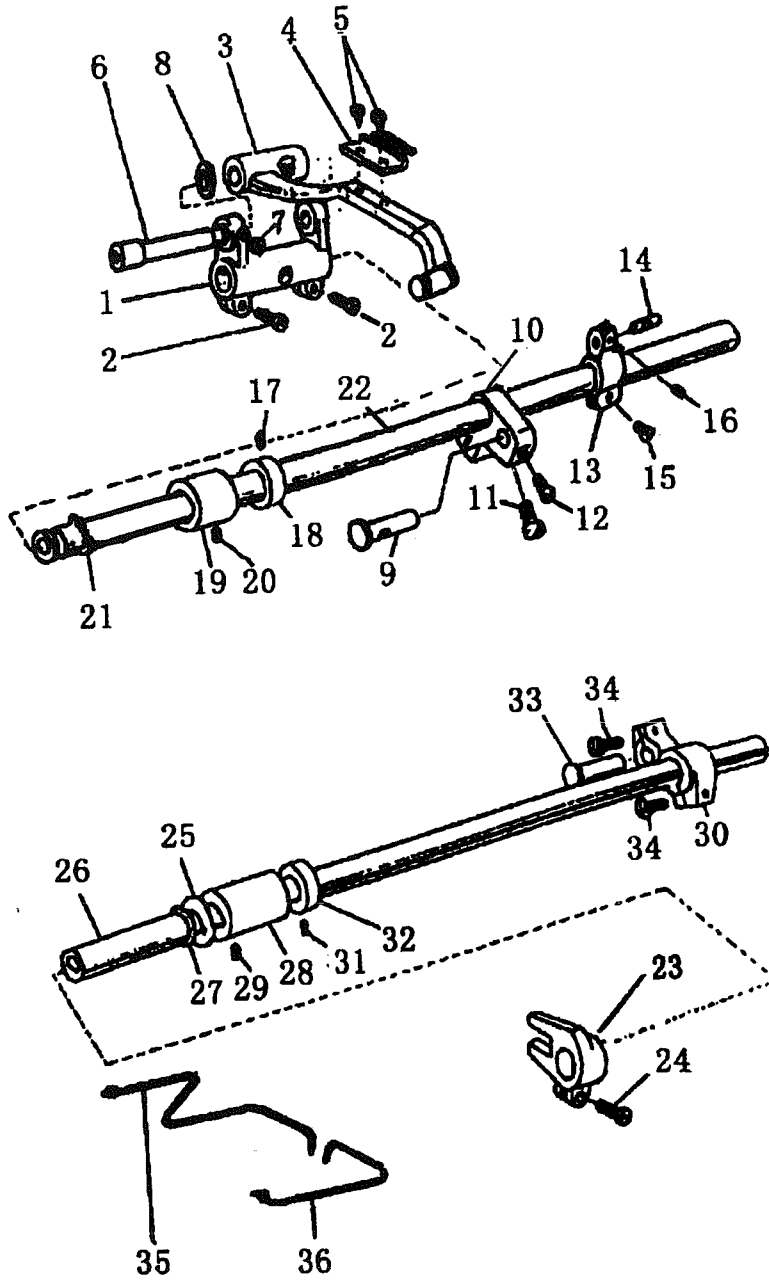

D. FEEDING AND FEED LIFTING MECHANISM

Fig. No.	Part No.	Description	GC0318-2A	GC0318-2H	GC0318-2B	GC0318-2AD	Remarks
D01	HA104G0011	Feed rock shaft crank (left)	1	1	1	1	
D02	HA304G0656	Screw	2	2	2	2	SM3/16 (28) × 15
D03	H6507G7101	Feed bar assay	1	1	1	1	
D04	HA104G0653	Feed dog	1			1	
D04	H2900G2010	Feed dog		1			
D04	H6521B8001	Feed dog			1		
D05	HA104G0654	Screw	2	2	2	2	SM1/8 (44) × 6
D06	HA705J0654	Hinge pin for feed regulator	1	1	1	1	
D07	HA300C2030	Screw	1	1	1	1	SM11/64 (40) × 8
D08	HA104G0656	Washer	1	1	1	1	
D09	H6505G8001	Hinge pin	1	1	1	1	
D10	H6504G8001	Feed rock shaft crank (right)	1	1	1	1	
D11	HA104G0012	Screw	2	2	2	2	SM3/16 (28) × 12
D12	H6505G8001	Screw.	1	1	1	1	
D13	HA8211C205	Feed rock shaft crank (right)	1	1	1	1	
D14	HA8311CB03	Link stud					
D15	HA8211C205	Screw	1	1	1	1	
D16	HA8311C803	Screw					
D17	HA105D0662	Set screw	2	2	2	2	SM1/4 (40) × 4
D18	HA108G0661	Collar	1	1	1	1	
D19	H2100G2020	Bushing for feed rock shaft	1	1	1	1	
D20	HA305E0662	Set screw	1	1	1	1	SM15/64 (28) × 4
D21	H007009150	C-type stop ring	1	1	1	1	
D22	H2100G2010	Feed rock shaft	1	1	1	1	
D23	HA304G0655	Oil braid	1	1	1	1	
D24	HA305G0664	Oil braid	1	1	1	1	
D25	HA100G2130	Washer	1	1	1	1	
D26	HA108G0661	Collar for feed lifting rock shaft	1	1	1	1	
D27	HA704K0652	Feed lifting rock shaft	1	1	1	1	
D28	HA100G2120	Bushing for feed lifting rock shaft	1	1	1	1	
D29	HA100C2020	Set screw	1	1	1	1	SM15/64 (28) × 10
D30	H007009150	C-type stop ring	1	1	1	1	
D31	HA105D0662	Screw	2	2	2	2	SM1/4 (40) × 4
D32	HA111G0683	Screw	1	1	1	1	SM11/64 (40) × 12
D33	HA306G0671	Feed lifting rock shaft crank(right)	1	1	1	1	
D34	HA100G2070	Hinge pin	1	1	1	1	
D35	HA104G0012	Screw	2	2	2	2	SM3/16 (28) × 12
D36	H1204D0651	Feed lifting rock shaft crank(left)	1	1	1	1	

E. PRESSER FOOT MECHANISM

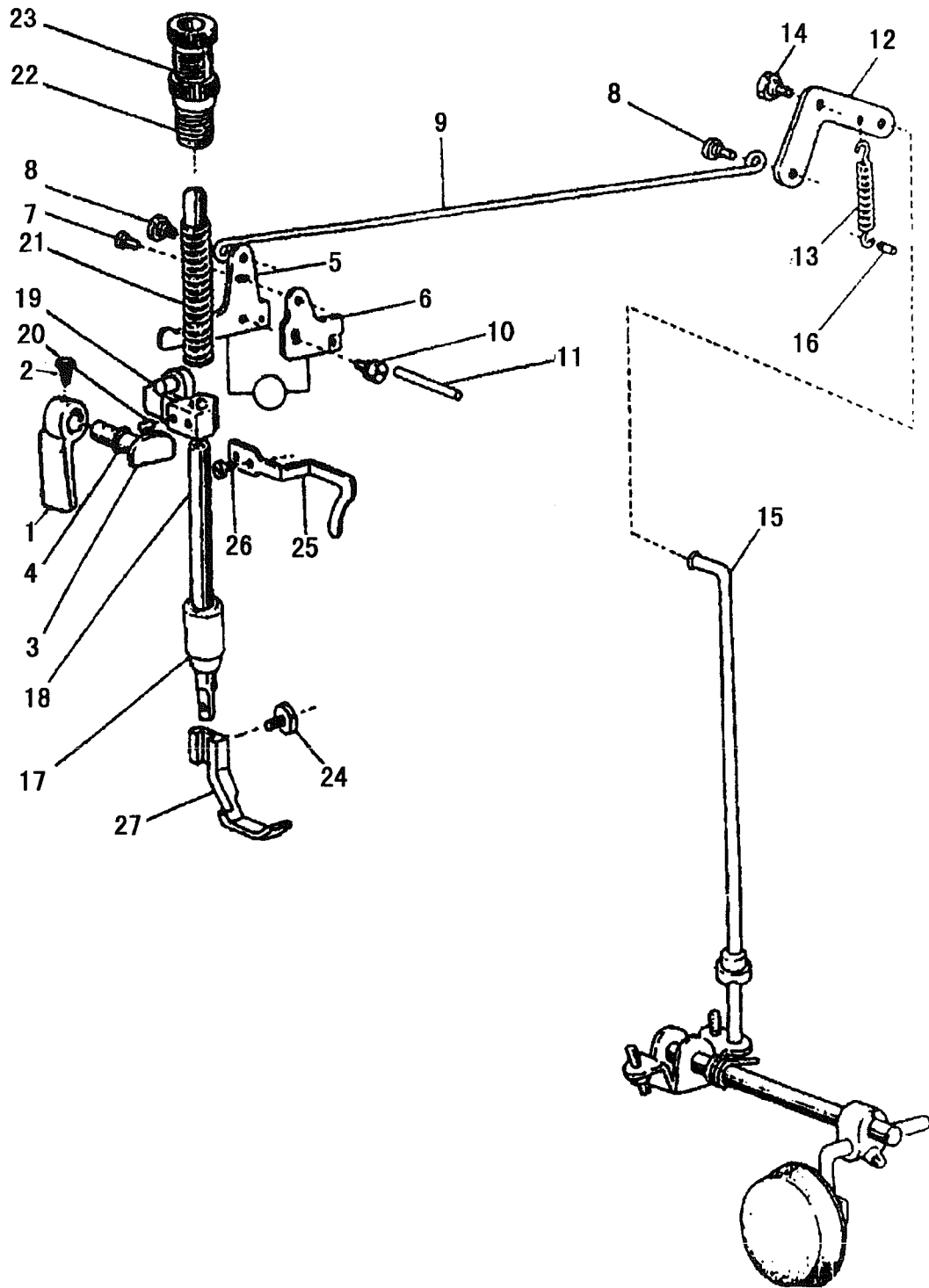

E.PRESSER FOOT MECHANISM

Fig. No.	Part No.	Description	GC0318-2A	GC0318-2H	GC0318-2B	GC0318-2AD	Remarks
E01	H2104H0651	Presser bar lifter	1	1	1	1	
E02	HA100B2110	Set screw	1	1	1	1	SM11/64 (40) × 5
E03	H2104H0661	Presser bar lifting cam	1		1	1	
E04	HA300H2080	Oil seal fot presser bar litting cam	1	1	1	1	8 × 1.9
E05	HA107H1011	Knee lifter lever (left)	1	1	1	1	
E06	HA305H6611	Tension releasing cam	1	1	1	1	
E07	HA107H1013	Screw	1	1	1	1	SM11/64 (40) × 6
E08	HA107H0662	Hinged screw	2	2	2	2	SM3/16 (28) × 3.5
E09	HA107H0663	Knee lifter rod	1	1	1	1	
E10	HA100H2050	Bolt	1	1	1	1	SM15/64 (28) × 13
E11	HA100H2060	Tension releasing pin	1	1	1	1	
E12	HA110H0671	Knee lifter lever (right)	1	1	1	1	
E13	H3211E0692	Spring	1	1	1	1	
E14	HA100H2050	Bolt for knee lifter lever	1	1	1	1	SM15/64 (28) × 10
E15	HA306H0671	Knee lifter connecting rod	1	1	1	1	
E16	HA720B0651	Pin for spring	1	1	1	1	
E17	HA300H2090	Presser bar bushing	1	1	1	1	
E18	H2000I2010	Presser bar	1	1	1	1	
E19	HM305H8001	Presser bar lifting bracket	1	1	1	1	
E20	HA3411D308	Set screw	1	1	1	1	SM15/64 (28) × 7
E21	H1100H2020	Presser spring	1	1	1	1	
E22	H2005I0065	Pressure regulating thumb screw	1	1	1	1	SM1/2 (28) × 43
E23	HA117H0692	Lock nut	1	1	1	1	
E24	HA100H2150	Set screw	1	1	1	1	SM9/64 (40) × 11
E25	HA300H2120	Upper thread guide	1	1	1	1	
E26	HA100C2040	Screw	1	1	1	1	SM11/64 (40) × 5
E27	H2000I2040	Presser loot complete	1			1	
E27	H2900H2020	Presser loot complete		1			
E27	H6522B8001	Presser loot complete			1		

F. PRESSER LIFTING, FEEDING MECHANISM

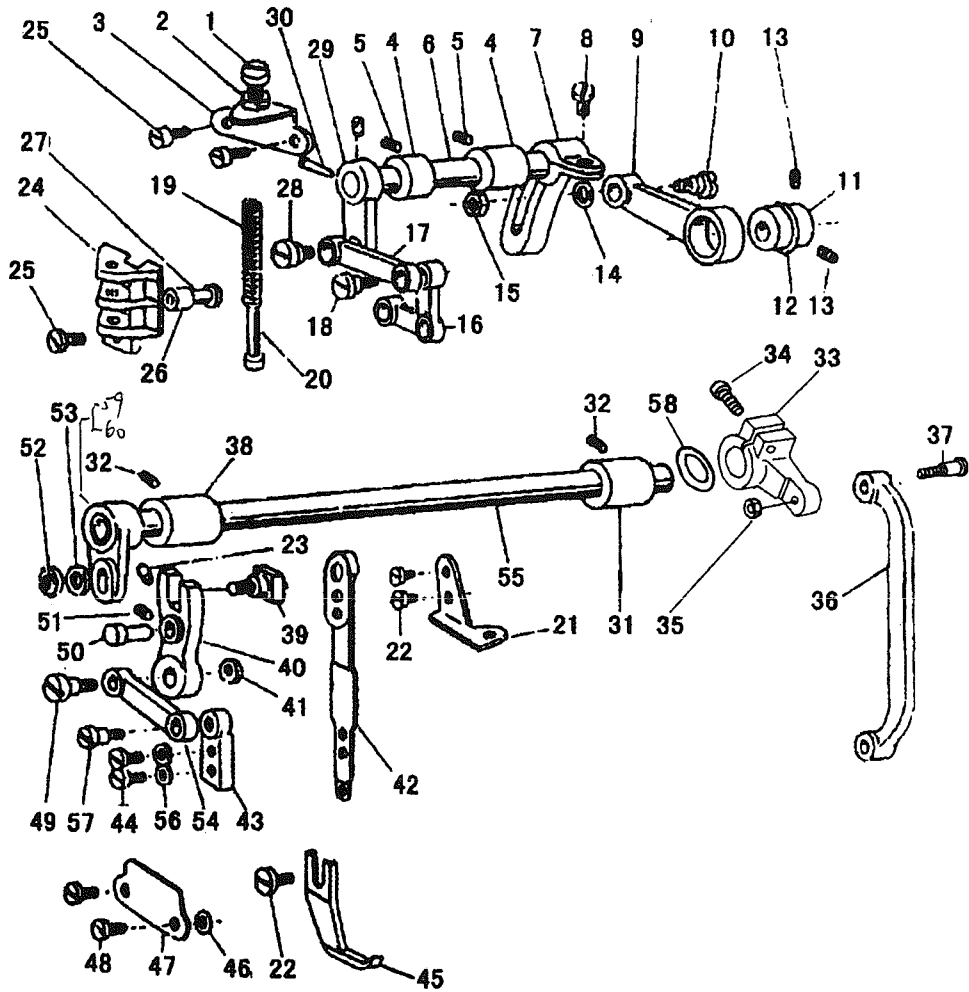

F. PRESSER LIFTING、 FEEDING MECHANISM

Fig. No.	Part No.	Description	GC0318-2A	GC0318-2H	GC0318-2B	GC0318-2AD	Remarks
F01	H2010J0065	Lifting presser adjusting screw	1	1	1	1	SM9/32 (28) × 35
F02	H2010J0066	Lifting presser adjusting nut	1	1	1	1	SM9/32 (28)
F03	H2000J2060	Lifting presser bracket for spring	1	1	1	1	
F04	H2009B0068	Presser lifting shaft bushing	2	2	2	2	
F05	HA100B2110	Screw	2	2	2	2	
F06	H2011J0066	Shaft	2	2	2	2	
F07	H2100I2010	Presser lifting shaft	1	1	1	1	
F08	H2012N0652	Set screw	1	1	1	1	
F09	H2104I0065	Eccentric wheel rod	1	1	1	1	
F10	H2000J2100	Set screw	1	1	1	1	M6 (0.75) × 29
F11	H2014J0652	Eccentric wheel	1	1	1	1	
F12	H007009250	C-type stop ring	1	1	1	1	GB/T894.1 25
F13	HA307C0662	Screw	2	2	2	2	SM1/4 (40) × 6
F14	H2013J0065	Washer	1	1	1	1	
F15	H0030020608	Nut	1	1	1	1	M6 × 0.75
F16	H2100I2020	Presser feed crank	1	1	1	1	
F17	H2004J0652	Presser feed crank link	1	1	1	1	
F18	H2004J0653	Screw	1	1	1	1	SM3/16 (28) × 12.6
F19	H2100I2190	Lifting presser spring	1	1	1	1	
F20	H2007J0066	Presser spring guide	1	1	1	1	
F21	H2004J0658	Lifting presser guide plate	1	1	1	1	
F22	HA100H2150	Screw	1	1	1	1	SM9/64 (40) × 13
F23	H609025180	Pin	1	1	1	1	GB/T879.1 2.5 × 18
F24	H2000J2020	Lifting presser plate	2	2	2	2	
F25	H2000I2050	Screw	1	1	1	1	SM9/64 (40) × 10
F26	H2000J2030	Lifting presser spring guide pin	1	1	1	1	
F27	H2004J0655	Feed crank guide shaft	1	1	1	1	
F28	H2004J0662	Screw	1	1	1	1	SM1/4 (40) × 15
F29	H2011J0065	Presser lifting crank	1	1	1	1	
F30	H602040200	Pin	1	1	1	1	GB/T117 4 × 20
F31	H3209B0065	Presser swing shaft bushing (right)	1	1	1	1	
F32	HA100B2110	Screw	2	2	2	2	SM11/64 (40) × 5.5
F33	H6013F8001	Presser swing crank (right)	1	1	1	1	
F34	H6017F8001	Screw	1	1	1	1	SM1/4 (24 × 19.7)
F35	H2010J0066	Lifting presser adjusting nut	1	1	1	1	SM9/32 (28)
F36	H6505I8001	Presser swing crank (right) rod	1	1	1	1	
F37	H2012N0066	Screw	1	1	1	1	SM9/32 (28) × 28
F38	H2100I2060	Presser swing shaft bushing (left)	1	1	1	1	
F39	H2121I0065	Lifting presser sway crank shaft compl	1	1	1	1	
F40	H2013N0069	Lifting presser sway crank	1	1	1	1	
F41	H2008N0066	Lock nut	1	1	1	1	SM1/4 (40)
F42	H2004J0654	Presser rod	1	1	1	1	
F43	H2004J0661	Presser rod guide	1	1	1	1	

F. PRESSER LIFTING、FEEDING MECHANISM

Fig. No.	Part No.	Description	GC0318-2A	GC0318-2H	GC0318-2B	GC0318-2AD	Remarks
F44	H2004J0067	Screw	2	2	2	2	SM9/64(40) × 9
F45	H2100I2040	Out presser	1			1	
F45	H2900I2020	Out presser		1			
F45	H6525B8001	Out presser			1		
F46	H2000N0040	Space for presser rod plate	2	2	2	2	
F47	H2000N0030	Lifting presser rod plate	1	1	1	1	
F48	HA111G0683	Screw	2	2	2	2	SM11/64(40) × 14.5
F49	H2008N0065	Screw	1	1	1	1	SM1/4(40) × 26
F50	H2013N0066	Lifting presser sway crank guide pin	1	1	1	1	SM1/4(40)
F51	H2100I2070	Screw	1	1	1	1	SM3/16(32) × 7
F52	H2013N0067	Presser crank connecting nut	1	1	1	1	SM1/4(24)
F53	H2013J0065	Washer	1	1	1	1	
F54	H2013N0070	Presser swing crank(left)	1	1	1	1	
F55	HM304I8001	Presser swing shaft	1	1	1	1	
F56	HA100I2050	Washer	1	1	1	1	
F57	H2004J0662	Screw	1	1	1	1	SM1/4(40) × 15
F58	H6018F8001	O-ring	1	1	1	1	
F59	H6016F8001	Upper feed rock shaft crank(left)	1	1	1	1	
F60	H6017F8001	Screw	1	1	1	1	SM15/64(28) × 18

G. OIL LUBRICATION MECHANISM

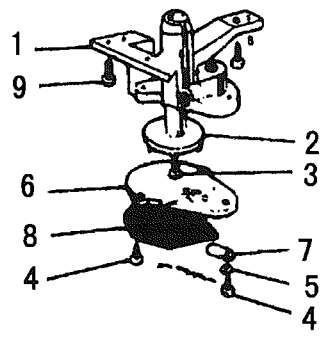
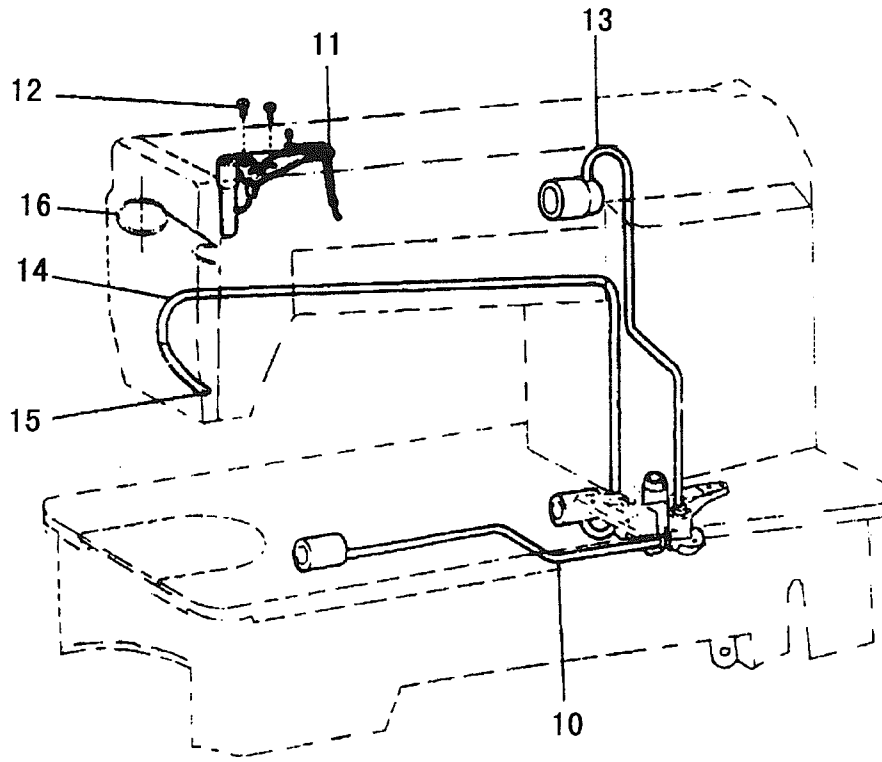

G.OIL LUBRICATION MECHANISM

Fig. No.	Part No.	Description	GC0318-2A	GC0318-2H	GC0318-2B	GC0318-2AD	Remarks
G01	HA100I2010	Oil pump body	1	1	1	1	
G02	H6010I8001	Oil pump impeller	1	1	1	1	
G03	HA100I2090	Screw	1	1	1	1	SM11/64(40) × 13
G04	HA300I2050	Screw	3	3	3	3	
G05	HA100I2050	Spring washer	1	1	1	1	
G06	H6012I8001	Oil pump fitting plate	1	1	1	1	
G07	HA100I2070	Oil adjusting plate	1	1	1	1	
G08	HA111I0065	Oil pump screen complete	1	1	1	1	
G09	HA100I2090	Screw	3	3	3	3	SM11/64(40) × 13
G10	HA113I0066	Oil pipe for hook shaft	1	1	1	1	
G11	HA304I0065	Oil braid fitting plate	1	1	1	1	
G12	HA100I2020	Screw	2	2	2	2	SM9/64(40) × 11
G13	H5604G0065	Oil pipe for arm shaft	1	1	1	1	
G14	HA305I0661	Oil return pipe	1	1	1	1	
G15	HA100I2150	Felt pouch	1	1	1	1	
G16	HA300I2060	pipe holder	1	1	1	1	

H.THREAD TRIMMER MECHANISM

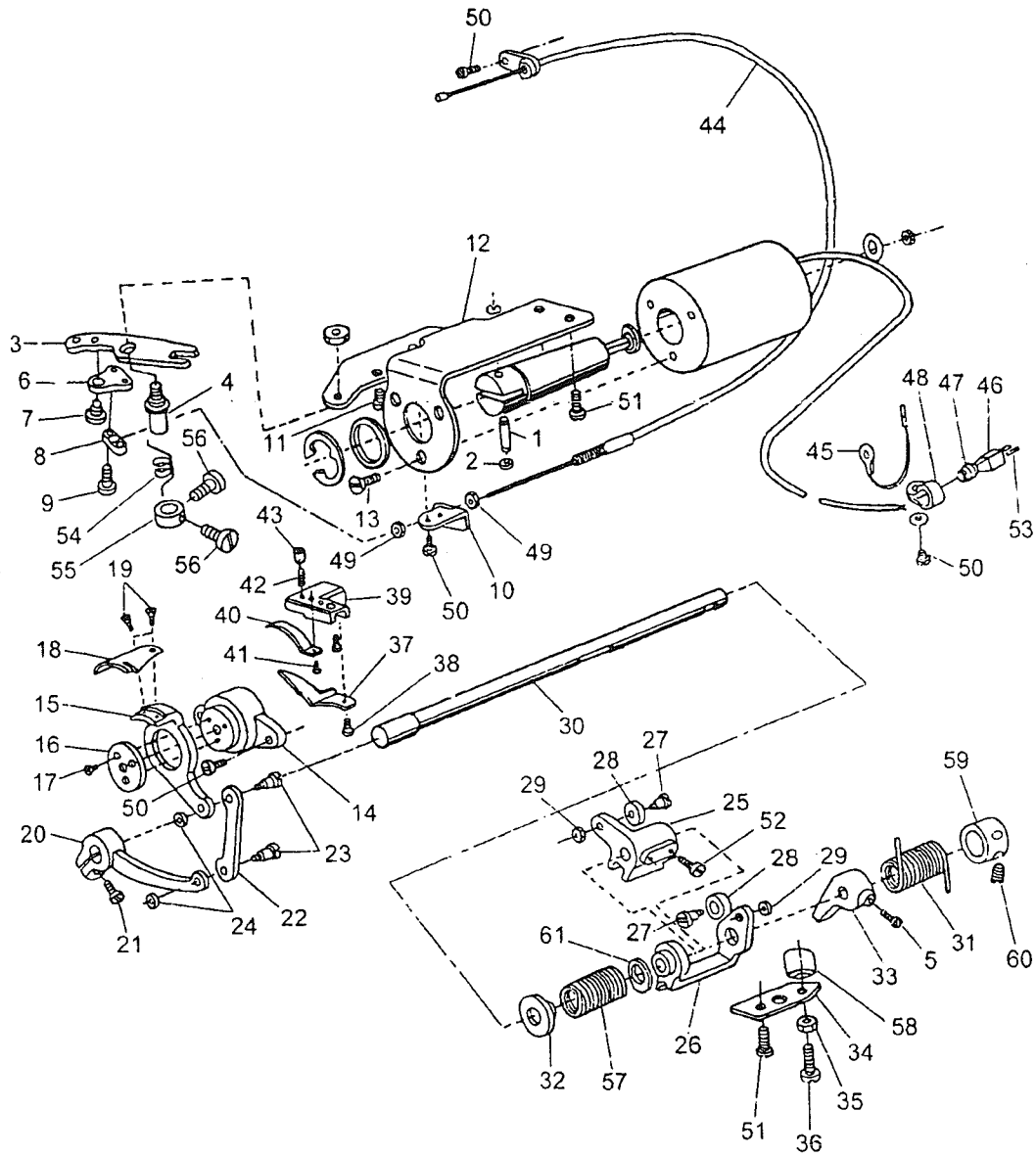

H.THREAD TRIMMER MECHANISM

Fig. No.	Part No.	Description	GC0318-2A	GC0318-2H	GC0318-2B	GC0318-2AD	Remarks
H01	HA712N0692	Link stud				1	
H02	H007013040	E-type ring 4				2	
H03	HA712N0698	Thread trimmer driving lever				1	
H04	HA712N0695	Stud screw				1	
H05	HA113F0684	Set screw				1	
H06	HA712N6910	Flexible wire bracket				1	
H07	HA712N0699	Set screw				1	
H08	HA712N6911	Link bracket				1	
H09	HA712N6912	Set screw				2	
H10	HA712N6913	Holder				1	
H11	HA100E2150	Set screw				1	
H12	HA7511N212	Solenoid bracket				1	
H13		P-type screw				3	
H14	HA704N1111	Knife holding bracket saddle				1	
H15	HA904N1111	Knife holding bracket saddle (left)				1	
H16	HA704N1113	Washer				1	
H17	HA704N1114	Set screw				3	
H18	H2806H8001	Movable knife (left)				1	
H19	HA7111N704	Set screw				2	
H20	HA7111N604	Knife driving crank				1	
H21	HA719B7011	Set screw				1	
H22	HA7111N404	Link				1	
H23	HA7111N204	Set screw				2	
H24	HA7111N304	Nut				2	
H25	HA7211N106	Cam follower crank 1				1	
H26	HA7211N206	Cam follower crank 2				1	
H27	HA7221N206	Roller stud				2	
H28	HA7221N106	Roller				2	
H29	HA706N0663	Nut				2	
H30	HA900N0020	Knife driving shaft				1	
H31	HA700N0110	Coil spring				1	
H32	HA700N0050	Brshing				1	
H33	HA906N0661	Stopper lever				1	
H34	HA710N0682	Lever stopper plate				1	
H35	HA710N0683	Nut				1	
H36	HA7411N110	Set screw				1	
H37	H22121H204	Thread finger				1	
H38	HA7311CH06	Set screw				3	
H39	HA7121N104	Bracket for fixed blade				1	
H40	H22121H104	Fixed blade				1	
H41	HA7121N304	Set screw				1	
H42	HA7121N604	screw				1	
H43	HA7121N704	Nut				1	

H.THREAD TRIMMER MECHANISM

Fig. No.	Part No.	Description	GC0318-2A	GC0318-2H	GC0318-2B	GC0318-2AD	Remarks
H44	HA713N0702	Flexible wire				1	
H45	HA705Q0065	Grounded wire				1	
H46	HA700Q0010	Connector plug				1	
H47	HA70400657	Gasket				1	
H48	HA708P0668	Cord holder HP-3N				1	
H49	H003002050	Nut M5				2	
H50	HA300B2170	Set screw				5	
H51	HA700N0080	Set screw				4	
H52	HA113F0684	Set screw				2	
H53	HA7641B319	Adaptor				1	
H54	HA712N0697	Spring for thread trimmer driving lever				1	
H55	HA712N0696	Collar for thread trimmer driving lever				1	
H56	HA7311CC06	Set screw				2	
H57	HA700N0040	Coil spring				1	
H58	HA7411N210	Dead block				1	
H59	HA715N0711	Collar with screw				1	
H60	HA105D0662	Set screw				1	
H61	HA706N0664	Washer				1	

I.TOUCH BACK MECHANISM & DETECTOR MECHANISM

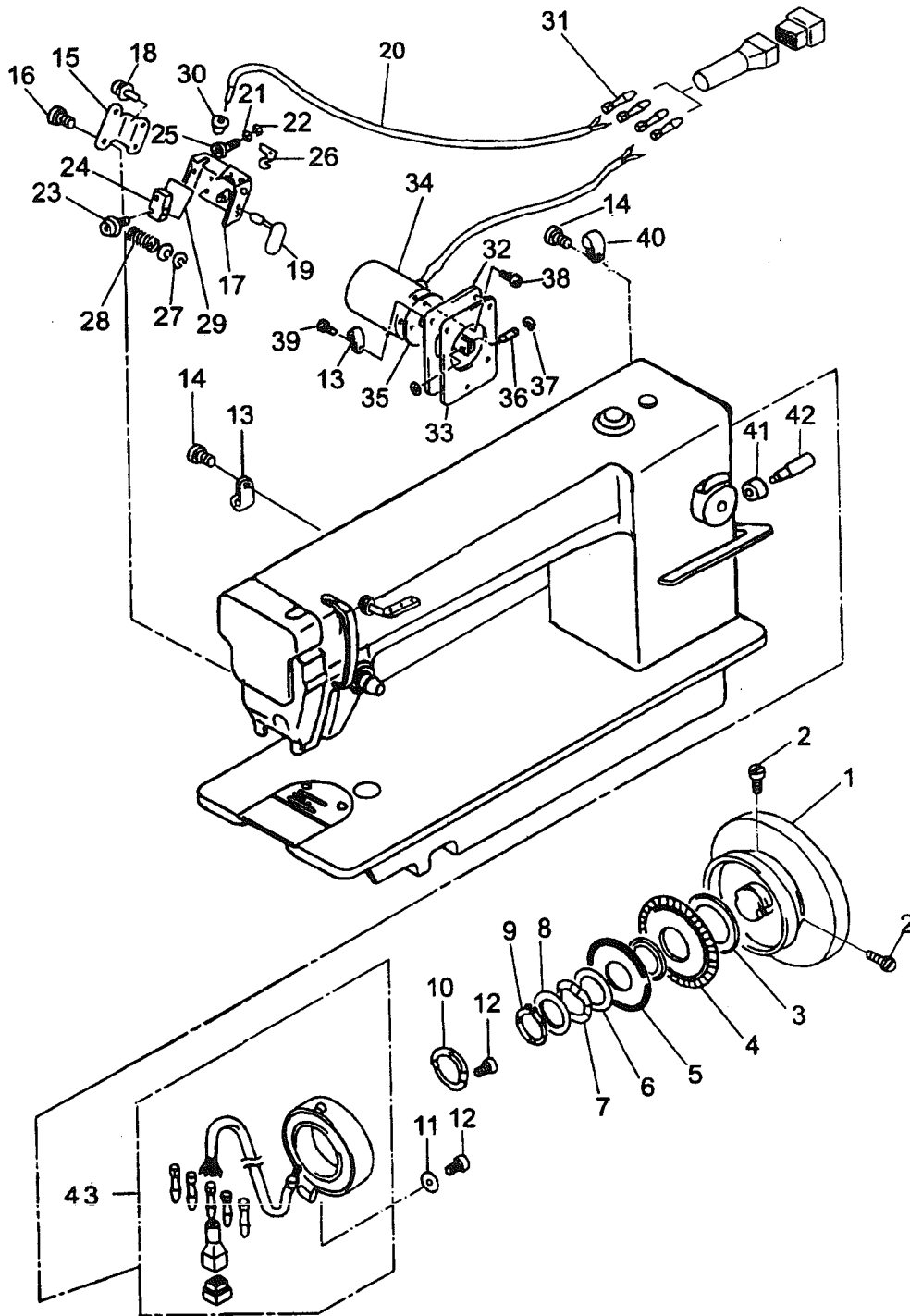

I.TOUCH BACK MECHANISM & DETECTOR MECHANISM

Fig. No.	Part No.	Description	GC0318-2A	GC0318-2H	GC0318-2B	GC0318-2AD	Remarks
I01	H2204I0651	Pulley				1	
I02	HA110D0672	Screw				2	
I03	HA700R0030	Spacer 1				2	
I04	HA700R0010	Speed command disc 1				1	
I05	HA700R0020	Speed command disc 2				1	
I06	HA700R0040	Spacer 2				1	
I07	HA700R0050	Supporter spring				1	
I08	HA700R0060	Washer				1	
I09	H007009300	C-type ring				1	
I10	HA703R0066	Detector bracket assay				1	
I11	HA703R0067	Washer				1	
I12	HA300C2030	Screw				3	
I13	HA708P0668	Cord holder				2	
I14	HA300B2170	Screw				2	
I15	HN605K8001	Bracket				1	
I16	HA300B2160	Screw				2	
I17	H2205I0661	Bracket for touch switch				1	
I18	HA7221P508	Screw				2	
I19	HA70400021	Push button				1	
I20	HA71610104	Vinyl cap-trire cable for touch switch				1	
I21	HA70406512	Washer				2	
I22	HA70406511	Washer				2	
I23	HA70406510	Screw				2	
I24	HA70400655	Micro switch				1	
I25	HA70400659	Screw				2	
I26	HA70400654	Spring plate				1	
I27	H007013030	E-type ring				2	
I28	HA70400653	Spring				1	
I29	HA70400658	Insulator set				1	
I30	HA70400657	Rubber plug				1	
I31	HA7641B319	Terminal pin				2	
I32	H6010K8001	Arm bed cover				1	
I33	H6011K8001	Gasket for arm bed cover				1	
I34	H2206I0673	Solenoid assay for touch black				1	
I35	H2206I0672	Washer				1	
I36	HA712N0692	Pin				1	
I37	H007013040	E-type ring				1	
I38	HA300C2030	Screw				4	
I39	HA300B2160	Screw				5	
I40	HA700Q0050	Cord holder				1	
I41	H2204G0652	Rubber plug				1	
I42	H2204G0651	Screw				1	
I43	HA700R0000	Detector bracket assay				1	

J. ACCESSORIES

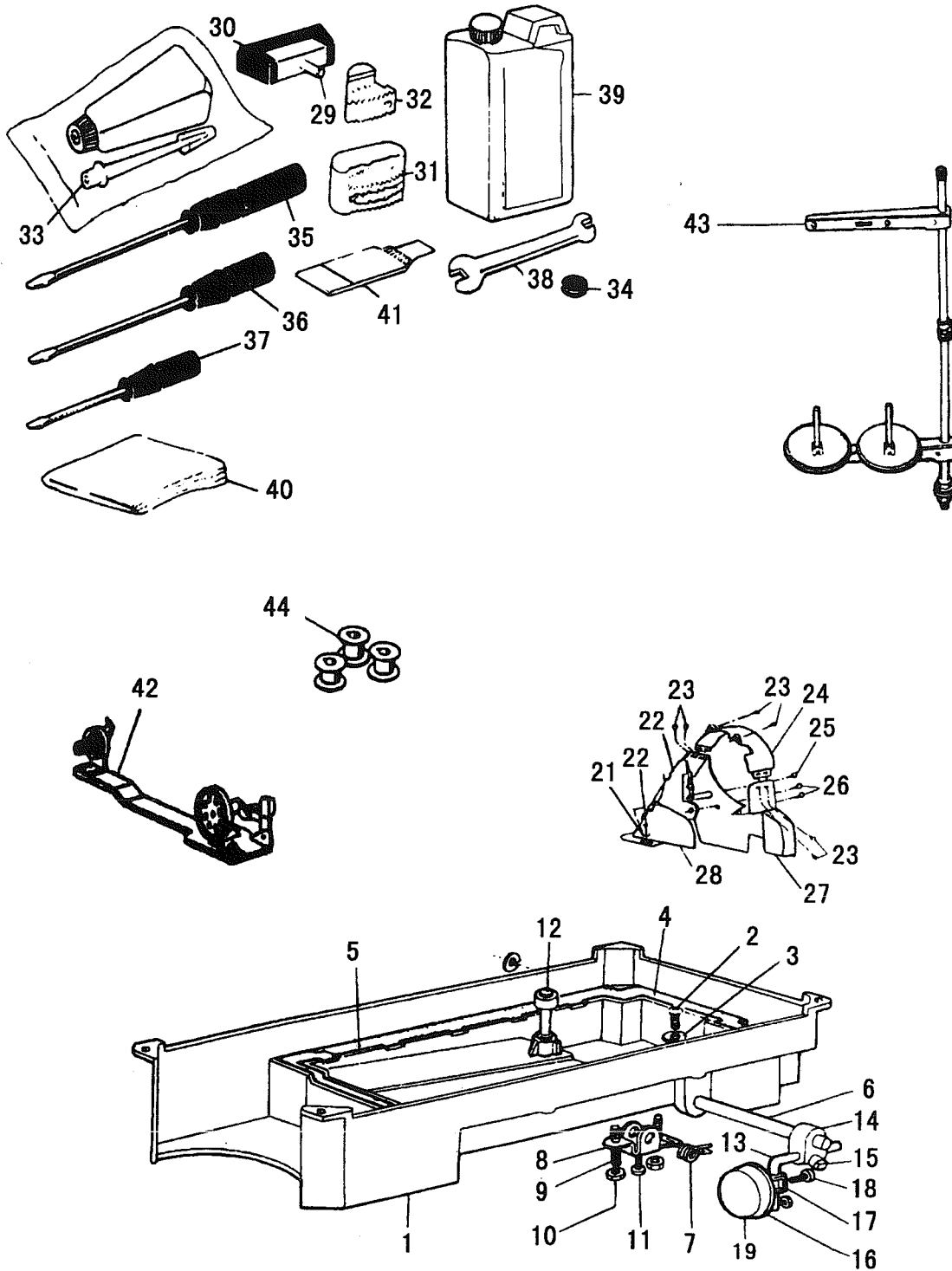

J.ACCESSORIES

Fig. No.	Part No.	Description	GC0318-2A	GC0318-2H	GC0318-2B	GC0318-2AD	Remarks
J01	HA304J0651	Oil seservoir	1	1	1	1	
J02	HA104J0652	Oil drain screw	1	1	1	1	SM5/16(28)×10
J03	HA104J0653	Washer	1	1	1	1	
J04	HA104J0654	Gasket for oil reservoir (small)	1	1	1	1	
J05	HA104J0655	Gasket for oil reservoir (big)	1	1	1	1	
J06	HA300J2160	Hinge pin for knee lifter	1	1	1	1	
J07	HA104J0657	Backspring for knee lifter	1	1	1	1	
J08	HA104J0658	Knee lifter stop bracket	1	1	1	1	
J09	HA104J0659	Adjusting screw	2	2	2	2	SM15/64(28)×28
J10	HA104J6510	Lock nut	2	2	2	2	
J11	HA110D0672	Screw	1	1	1	1	SM15/64(28)×14.8
J12	HA106J0661	Knee lifter lifting rod	1	1	1	1	
J13	HA106J0662	Knee lifter bell crank	1	1	1	1	
J14	HA106J0663	Joint for knee lifter bell crank	2	2	2	2	
J15	HA300J2180	Set screw	1	1	1	1	SM5/16(28)×16
J16	HA106J0665	Knee lifter plate	1	1	1	1	
J17	HA106J0666	Bracket for knee lifter plate	1	1	1	1	
J18	HA106J0667	Set screw	1	1	1	1	SM15/64(28)×8
J19	HA106J0668	Pad for knee lifter plate	4	4	4	4	
J20	H801045200	Screw	4	4	4	4	GB/T99 4.5×20
J21	HA300J2230	Washer	1	1	1	1	
J22	H200800068	Belt(upper)	6	6	6	6	
J23	HA300B2170	Screw	1	1	1	1	SM11/64(40)×8
J24	H200800671	Belt mark complrte	1	1	1	1	
J25	HA300J2250	Screw	2	2	2	2	M4×12.5
J26	HA300J2280	Screw	1	1	1	1	SM15/64(28)×8
J27	H200800067	Belt (lower)	1	1	1	1	
J28	HA305J0665	Belt complete	1	1	1	1	
J29	HA110J0701	Hinge of machine head	2	2	2	2	
J30	HA307J0671	Rubber socket for hinge	2	2	2	2	
J31	HA300J2050	Rubber cushion(big)	2	2	2	2	
J32	HA300J2060	Rubber cushion(small)	2	2	2	2	
J33	HA100J2110	Oiler	1	1	1	1	
J34	HA100J2120	Magnet	1	1	1	1	
J35	HA300J2070	Screw driver(long)	1	1	1	1	
J36	HA300J2200	Screw driver(medium)	1	1	1	1	
J37	HA300J2210	Screw driver(short)	1	1	1	1	
J38	HA300J2220	Double-end wrench	1	1	1	1	
J39	HA100J2170	Oil container	1	1	1	1	
J40	HA100J2180	Vinyl cover	1	1	1	1	
J41	H2000G2030	Needle	4			4	
J41	HA700G2040	Needle		4			
J41	H6524B8001	Needle			4		

J.ACCESSORIES

Fig. No.	Part No.	Description	GC0318-2A	GC0318-2H	GC0318-2B	GC0318-2AD	Remarks
J42	HA905S0066	Bobbin winder assy	1		1	1	
J42	HA706S0067	Bobbin winder assy		1			
J43	HA200J2030	Washer	1	1	1	1	
J44	H1100E2010	Bobbin	3		3	3	
J44	HA100E2170	Bobbin		3			

SHANGHAI HUIGONG NO.3 SEWING MACHINE FACTORY

ADD: 1418, Yishan Road, Shanghai, China

Zip Code: 201103

Overseas Business: TEL: 86-21-64853303 FAX: 86-21-64854304

E-mail: highlead@online.sh.cn <http://www.highlead.com.cn>

The description covered in this manual is subject to change for improvement of the commodity without notice

2006.8. Printed